



900



SINGLE POINT

Suspension Series

Configurations & Parts Identification



Advancing the Practical Application of Suspension Technology

Springfield, MO ■ (800) 654-8824 ■ (417) 862-5012
Fax (417) 862-2317 ■ www.hutchensindustries.com

Copyright © 2012 Hutchens Industries

Table of Contents

Pgs. 1-2	Application, Capacity, Standard Features, Options	Pg. 9	Pre-Installation, Axle Installation
Pg. 3	How To Order	Pg. 10	Axle Installation (cont.), Preparing Trailer Frame For Mounting Tandem Assembly
Pg. 4	Axle Specifications and Mounting Heights Charts	Pg. 11	Installation Using Hutchens Mounting Brackets
Pg. 5	900 - 36 thru 70,000 lbs. Bill of Materials, Spring Identification Chart D	Pg. 12	Mounting Tandem Assembly To Trailer
Pgs. 6-7	900 Illustrated - 3 Leaf Shown	Pg. 13	Bump-Outs, Axle Alignment, Adjustment Plate Welding
Pg. 8	Trunnion Hanger Chart A, Trunnion Tube Chart B, Trunnion U-Bolt Chart C, Spring End Cap Chart E, Spring Seat Chart F, Axle U-Bolt Chart G	Pg. 14	Numerical Listing Of Parts, Important: Decal Note

Preface

In the mid-1950's Hutchens' engineers realized an urgent need for a heavier, more rugged, single point tandem that would allow more oscillation without wear and have an adjustable alignment feature. After thorough research and severe road testing, Hutchens introduced the Hutch 800 model suspension in weight capacities of 36,000, 42,000, 50,000 and 60,000 lbs.

The 800 single point suspension remained virtually unchanged until the very early 1970's. At that time a split trunnion casting, which permits easy maintenance and replacement of trunnion bushings should it become necessary, replaced the solid one-piece casting that had been used previously. This model was known as the 800A.

Still in the early 1970's Hutchens introduced the 800B. The 800B had inverted trunnion U-bolts that allowed easier maintenance since the trunnion U-bolt nuts were now on the underside of the suspension. Underslung axle configurations were added as well.

In the mid-1970's Hutchens began offering the 900 model single point suspension. The 900 offers many improvements over earlier single points offered to the market. Greater versatility of axle spacing and spring selection is provided through the use of a wide selection of springs specifically designed for different load carrying capacities. The 900 offered spring box ends for square axles as well as round axles.

In the late 1980's Hutchens introduced a lighter-weight, three-leaf spring, single point suspension in weight capacities of 44,000 and 50,000 lbs. Taking advantage of advances in leaf spring engineering and manufacturing technology, the three-leaf 903 redefined lightweight suspension performance in heavy-duty applications. The addition of this innovative spring to the rugged 900 series further broadened an already versatile suspension line.

In this booklet we define the 900 Series' Applications, Capacities, Features and Options. We also describe what information is required to order your 900 Series suspension. Isometric drawings and Bills of Materials are presented for easier identification of parts. An installation section is included as well. This 900 publication supersedes all previously issued materials relating to the 900 Series suspension, its installation and its usage. Usage of outdated materials can result in improper installation of the suspension. The last page of this booklet contains a Numerical Listing Of Parts found within this publication. Parts are listed in numerical order, and are followed by a parts description and page numbers on which they can be found.

Before beginning any installation procedures, the customer should read all installation instructions thoroughly. Should you have any questions concerning the 900 Series or any of its predecessors, please contact Hutchens for assistance.

Application

The 900 Series suspensions are designed for heavy-duty and/or off-road applications. The 900 is a single point suspension connected to the trailer frame by a trunnion located at the center of the suspension. This makes it ideal for logging, heavy load hauling and dump operations.

Capacity

The 900 Series suspensions are available in Gross Tandem Weight Ratings (G.T.W.R.) of 36,000, 42,000, 44,000, 50,000, 60,000 and 70,000 lbs.

Features

- ▶ Cast steel parts, wheelabrated and prime painted.
- ▶ Extra heavy-duty 5" wide leaf springs.
- ▶ Accurate spring alignment preserved by the use of rugged spring guides on the trunnion casting.
- ▶ A split trunnion casting permits easy maintenance and replacement of trunnion bushings.
- ▶ Axle alignment and realignment made possible by adjustable plates within the spring-end boxes. One adjustment plate on each axle is welded at the factory. After axle alignment is completed, the installer welds the other adjustment plate to ensure sustained axle alignment.
- ▶ For increased life and flexibility, thick rubber pads are used above the spring leaves in the axle boxes. This construction permits greater twist freedom in the spring box...a standard flexibility feature that reduces wear and promotes better ride characteristics.

Options

Standard 900 Series suspensions are available in capacities of 36,000, 42,000, 50,000, 60,000 and 70,000 lbs. Additionally, lightweight two-leaf and three-leaf units are available in capacities of 36,000, 44,000 and 50,000 lbs.

Numerous mounting heights (Mtg./ht. = the vertical distance from the center line of the axle to the top of the trunnion hanger), axle and trunnion combinations are possible. These include overslung (OS, springs over axles) and underslung (US, springs under axles) axle units as well as overslung (springs over trunnion) and underslung (springs under trunnion) trunnion configurations.

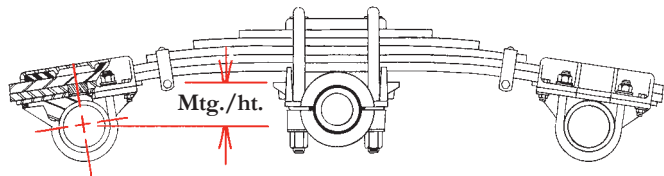

Overslung Axles – Overslung Trunnion
(Formerly Overslung Axles – Standard Trunnion)

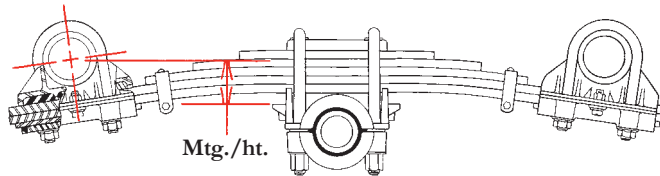

Underslung Axles – Overslung Trunnion
(Formerly Underslung Axles – Standard Trunnion)

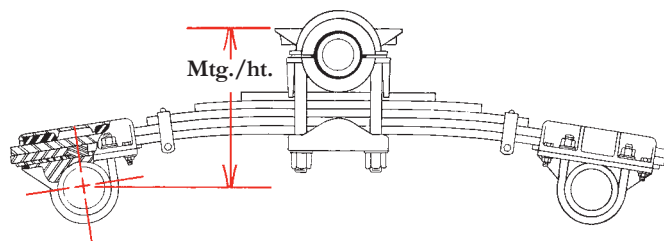

Overslung Axles – Underslung Trunnion
(Formerly Overslung Axles – Optional Trunnion)

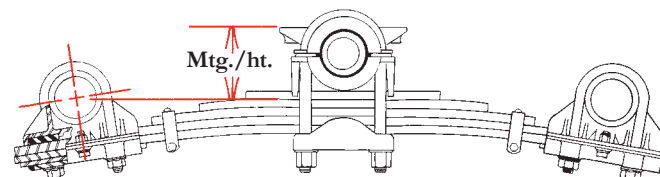

Underslung Axles – Underslung Trunnion
(Formerly Underslung Axles – Optional Trunnion)

Axle boxes to accommodate 5", 5 3/4" and 6" round axles or 5" x 5" square axles are available.

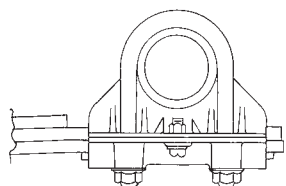

Axle Box for Round Axle

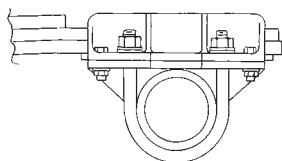

Axle Box for Square Axle

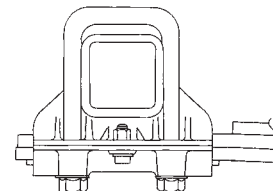
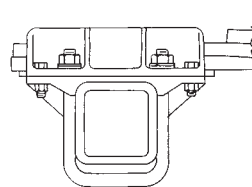

Several different axle centers (AC) are available. See Axle Specifications And Mounting Heights Charts on Page 4.

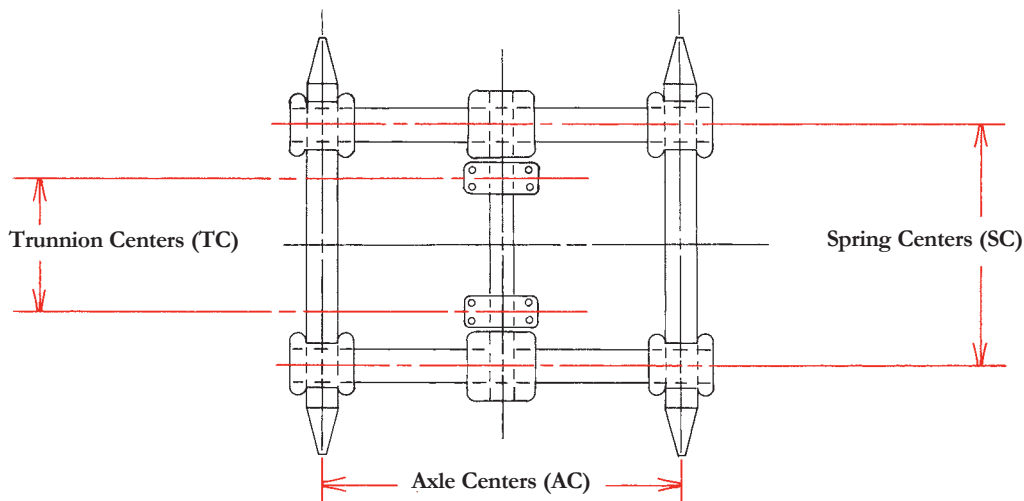

Standard spring centers (SC) for the 900 Series suspensions are 38". Other spring centers can be furnished upon request.

Trunnion hanger heights (TH) of 2 1/2", 4 1/2", 6 1/2" and 8 1/2" are available.

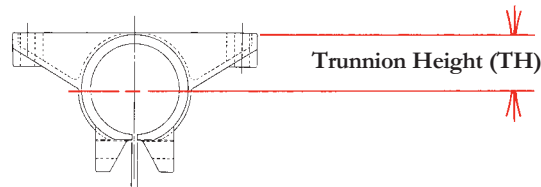

Standard trunnion hanger centers (TC) are 22 1/8" (for 38" spring centers). Trunnion centers of 20 1/8" can be specified while maintaining 38" spring centers.

Trunnion bushings of either rubber or Polyurethane ("free oscillating") are available. Unless otherwise specified, trunnion bushings are assumed to be rubber.

When installing your 900 Series suspension, adequate vertical clearance must be provided for the tires, springs and U-bolts. This is usually accomplished through the use of a mounting bracket or pedestal.

How To Order Your 900 Series Single Point Suspension System

With so many options available on the 900 Series suspensions, each unit must be ordered by a description of the unit desired. Any abbreviations listed are defined in the Options section of this booklet. Such abbreviations are commonly found in Hutchens suspension notation.

1. Determine which 900 Series suspension will meet your weight requirements - 36,000#, 42,000#, 44,000#, 50,000#, 60,000# or 70,000# GTWR.
2. Select a mounting height (Mtg./ht.) that corresponds to your particular situation. See Axle Specifications And Mounting Heights Charts on Page 4.
3. Axle configuration - Overslung or Underslung.
4. Axle size - 5", 5 3/4", 6" Round or 5" x 5" Square (Hutchens does not manufacture or sell axles).
5. Trunnion configuration - Overslung or Underslung.
6. Trunnion Hanger Height (TH) - 2 1/2", 4 1/2", 6 1/2" or 8 1/2". In many instances more than one combination will result in the same mounting height.
7. Axle Centers (AC) - See Axle Specifications And Mounting Heights Charts on Page 4.
8. Spring Centers (SC)
9. Trunnion Centers (TC)
10. To help ease the installation of your 900 Series suspension you may wish to order a pair of Hutch mounting brackets (Part #16793-01). See Fig. A below.

From this chart please note that mounting height is dependent upon:

3. Axle configuration - Overslung or Underslung.
4. Axle size - 5", 5 3/4", 6" Round or 5" x 5" Square (Hutchens does not manufacture or sell axles).
5. Trunnion configuration - Overslung or Underslung.
6. Trunnion Hanger Height (TH) - 2 1/2", 4 1/2", 6 1/2" or 8 1/2". In many instances more than one combination will result in the same mounting height.

Therefore, all the aforementioned factors should be taken into consideration when ordering as well as the following:

Example: A 900 Series suspension with a GTWR of 42,000 lbs., a mounting height of 4" for overslung (OS) 5" round axles, an overslung (OS) trunnion configuration with a trunnion hanger height (TH) of 2 1/2", axle centers (AC) of 50 1/2", spring centers (SC) of 38", and trunnion centers (TC) of 22 1/8" would be ordered as follows:

Quantity	Suspension Model	Axle Config.	Trunnion Config.	Axle Size	Trunnion Height	Axle Centers	Spring Centers	Trunnion Centers
1 ea.	900-42	OS (axles)	OS (trun.)	5" Rd.	2 1/2 TH	50 1/2 AC	38 SC	22 1/8 TC

Example: A 900 Series suspension with a GTWR of 50,000 lbs., a mounting height of 9 1/2" for underslung (US) 5" x 5" square axles, an underslung (US) trunnion configuration with a trunnion hanger height (TH) of 6 1/2", axle centers (AC) of 53", spring centers (SC) of 36", trunnion centers (TC) of 20 1/8" utilizing a three-leaf spring* and free oscillating trunnion bushings** would be ordered as follows:

Quantity	Suspension Model	Axle Config.	Trunnion Config.	Axle Size	Trunnion Height	Axle Centers	Spring Centers	Trunnion Centers	Spring * Type
1 ea.	900-50	US (axles)	US (trun.)	5" x 5" Sq.	6 1/2 TH	53 AC	36 SC	20 1/8 TC	3 leaf

w/ free oscillating bushing**

* Three-leaf springs are available for 44,000 and 50,000 lb. units only and must be specified.

** Must be specified.

Fig. A

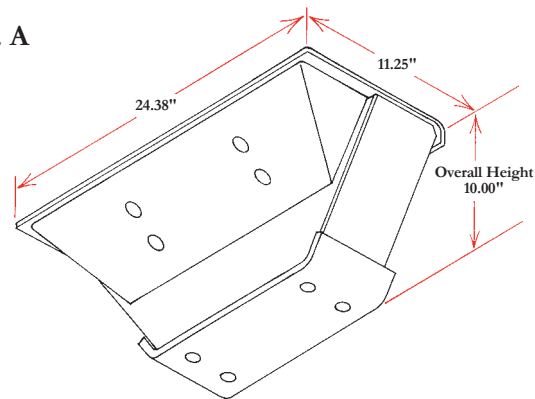

Overslung Axle Specifications And Mounting Heights For Models:

900-36 through 900-44 with 2.5 Trunnion Ht., 5" Rd. & 5" x 5" Sq. Axles

900-50 through 900-70 with 4.5 Trunnion Ht., 5" Rd. & 5" x 5" Sq. Axles

Model Description	Gross Tandem Weight Rating (GTWR)	Spring Number	Number of Spring Leaves	Nominal Axle Spacing		Mounting Height			
				Unloaded	Loaded	Overslung Trunnion		Underslung Trunnion	
						Unloaded	Loaded	Unloaded	Loaded
900-36	36,000	10054-00	5	48.00	48.75	4.00	3.00	15.00	14.00
900-36	36,000	11151-00	5	50.50	51.50	4.00	2.50	15.00	13.50
900-36	36,000	16258-01	Tapered 2	50.50	51.50	4.00	2.50	13.35	11.85
900-42	42,000	9997-00	6	48.00	48.75	4.00	3.00	15.75	14.75
900-42	42,000	9998-00	6	50.50	51.50	4.00	2.75	15.75	14.62
900-44	44,000	12258-01	Tapered 3	50.50	51.50	4.00	2.87	14.50	13.37
900-50	50,000	10055-00	7	48.00	48.75	6.00	5.00	18.50	17.12
900-50	50,000	9999-00	7	50.50	51.50	6.00	4.62	18.50	17.50
900-50	50,000	12258-01	Tapered 3	50.50	51.50	6.00	4.62	16.50	15.12
900-50	50,000	10000-00	8	54.00	55.25	6.50	5.00	19.75	18.25
900-60	60,000	10001-00	9	54.00	55.25	6.50	4.75	20.50	18.75
900-70	70,000	24967-01	10	54.00	55.25	6.50	4.75	21.38	19.63
With 4.5 Trunnion Height Add (900-36 thru 44)/(900-50 thru 70)						2.00/0.00	2.00/0.00	2.00/0.00	2.00/0.00
With 6.5 Trunnion Height Add (900-36 thru 44)/(900-50 thru 70)						4.00/2.00	4.00/2.00	4.00/2.00	4.00/2.00
With 8.5 Trunnion Height Add (900-36 thru 44)/(900-50 thru 70)						6.00/4.00	6.00/4.00	6.00/4.00	6.00/4.00
When 5.75" or 6" Rd. Axles Are Used Add						.50	.50	.50	.50

Mounting heights shown for models 900-50 thru 70 are based on a 4.50 high trunnion bracket. Do not use the 2.50 high bracket on models with 50,000 lbs. GTWR or greater.

Underslung Axle Specifications And Mounting Heights For Models:

900-36 through 900-44 with 2.5 Trunnion Ht., 5" Rd. & 5" x 5" Sq. Axles

900-50 through 900-70 with 4.5 Trunnion Ht., 5" Rd. & 5" x 5" Sq. Axles

Model Description	Gross Tandem Weight Rating (GTWR)	Spring Number	Number of Spring Leaves	Nominal Axle Spacing		Mounting Height			
				Unloaded	Loaded	Overslung Trunnion		Underslung Trunnion	
						Unloaded	Loaded	Unloaded	Loaded
900-36	36,000	10054-00	5	50.50	50.00	-4.25	-5.25	6.75	5.75
900-36	36,000	11151-00	5	53.00	52.25	-4.25	-5.75	6.75	5.25
900-36	36,000	16258-01	Tapered 2	53.00	52.25	-4.25	-5.75	5.10	3.60
900-42	42,000	9997-00	6	50.62	50.00	-5.00	-6.00	6.75	5.75
900-42	42,000	9998-00	6	53.00	52.25	-5.00	-6.25	6.75	5.50
900-44	44,000	12258-01	Tapered 3	53.00	52.25	-5.00	-6.12	5.50	4.37
900-50	50,000	10055-00	7	50.62	50.00	-3.00	-4.00	9.50	8.50
900-50	50,000	9999-00	7	53.00	52.25	-3.00	-4.37	9.50	8.12
900-50	50,000	12258-01	Tapered 3	53.00	52.25	-3.00	-4.37	7.50	6.12
900-50	50,000	10000-00	8	57.00	56.00	-2.50	-4.00	10.75	9.25
900-60	60,000	10001-00	9	57.00	56.00	-2.50	-4.25	11.50	9.75
900-70	70,000	24967-01	10	57.00	56.00	-2.50	-4.25	12.38	10.63
With 4.5 Trunnion Height Add (900-36 thru 44)/(900-50 thru 70)						2.00/0.00	2.00/0.00	2.00/0.00	2.00/0.00
With 6.5 Trunnion Height Add (900-36 thru 44)/(900-50 thru 70)						4.00/2.00	4.00/2.00	4.00/2.00	4.00/2.00
With 8.5 Trunnion Height Add (900-36 thru 44)/(900-50 thru 70)						6.00/4.00	6.00/4.00	6.00/4.00	6.00/4.00
When 5.75" or 6" Rd. Axles Are Used Subtract						-.50	-.50	-.50	-.50

Mounting heights shown for models 900-50 thru 70 are based on a 4.50 high trunnion bracket. Do not use the 2.50 high bracket on models with 50,000 lbs. GTWR or greater.

900 Tapered Leaf (shown) and Multi-Leaf - 36 thru 70,000

Bill of Materials

Item	Part No.	Quantity				Description
		Overslung Trunnion		Underslung Trunnion		
		Overslung Axle	Underslung Axle	Overslung Axle	Underslung Axle	
1	See Chart A, Page 8	2	2	2	2	Trunnion Hanger
2	10376-00	4	4	4	4	Hex Bolt 3/4" - 16 UNF x 4 1/2", GR5
3	895-00	2	2	2	2	Washer, 7GA x 4 1/32 ID x 5 3/4 OD
4	See Chart B, Page 8	1	1	1	1	Trunnion Tube
5	See Chart C, Page 8	4	4	4	4	U-Bolt, Trunnion
6	9640-00	2	2	0	0	Top Plate - Cast, Square U-Bolt
7	See Chart D, Below	2	2	2	2	Spring
8	See Chart E, Page 8	4	4	4	4	Spring End Cap
9	841-00	20	4	20	4	Hex Nut, Self Locking, 3/4" - 16 UNF
10	9293-00	16	8	16	8	Hex Bolt, 5/8" - 18 UNF x 2", GR5
11	817-00	32	0	32	0	Washer, 1/8" x 13/16 ID x 1 1/2 OD
12	814-00	8	8	8	8	Rubber Pad - Plain
13	10608-00	4	4	4	4	Adjustment Plate
14	See Chart F, Page 8	4	4	4	4	Spring Seat
15	10273-00	16	8	16	8	Washer, 1/8" x 21/32 ID x 1 15/16 OD
16	11513-03	16	8	16	8	Hex Locknut, 5/8" - 18 UNF
17	See Chart G, Page 8	8	8	8	8	U-Bolt - Axle
18	12919-01 [‡]	2	2	2	2	Galvanized Liner - .040 x 4.75 x 10.00
19	891-00	2	2	2	2	Trunnion Hub - Upper Half
20	890-00	2	2	2	2	Rubber Bushing - Trunnion Hub
	23276-01	2	2	2	2	Free Oscillating Trunnion Bushing*
21	898-00	2	2	—	—	Trunnion Hub - Lower Half
	892-00	—	—	2	2	Trunnion Hub - Lower Half
22	837-00	8	8	8	8	Washer, 1/8" x 1 1/4 ID x 2 1/4 OD
23	836-00	8	8	8	8	Hex Nut, 1 1/8" - 12 UNF x 1 1/2 HI
24	10562-00	0	16	0	16	Flange Locknut - 1-14 UNS, GRF
25	820-00	0	0	2	2	Spring Clamp Plate
26	10488-00	4	4	4	4	Pressure Plate, 5" x 5" Axle Only

Chart D - Spring Identification ** (Item #7)

Unit Weight Capacity (lbs.)	36,000	36,000	36,000	42,000	42,000	44/50,000	50,000	50,000	50,000	60,000	70,000
Number of Leaves	Tapered 2 [‡]	5	5	6	6	Tapered 3 [‡]	7	7	8	9	10
Spring Part No.	16258-01	10054-00	11151-00	9997-00	9998-00	12258-01	10055-00	9999-00	10000-00	10001-00	24967-01

* Available upon request, must be specified.

** For a detailed description of axle spacings, mounting heights, etc. obtained when utilizing the above springs, see the Axle Specifications And Mounting Heights Charts on Page 4.

‡ A galvanized liner is required on the tension surface (bottom side) of the spring when taper leaf (2 and 3 leaf) springs are utilized. Liners are not required on flat plate (5, 6, 7, 8, 9 and 10 leaf) springs.

Overslung Trunnion – Overslung Axle



Underslung Trunnion – Underslung Axle

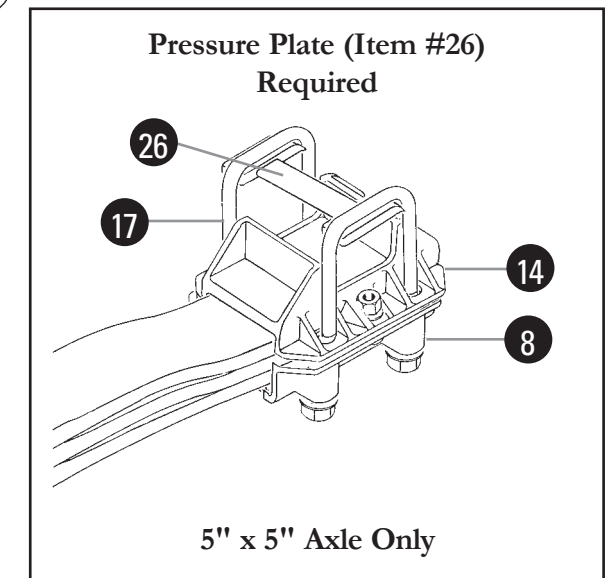
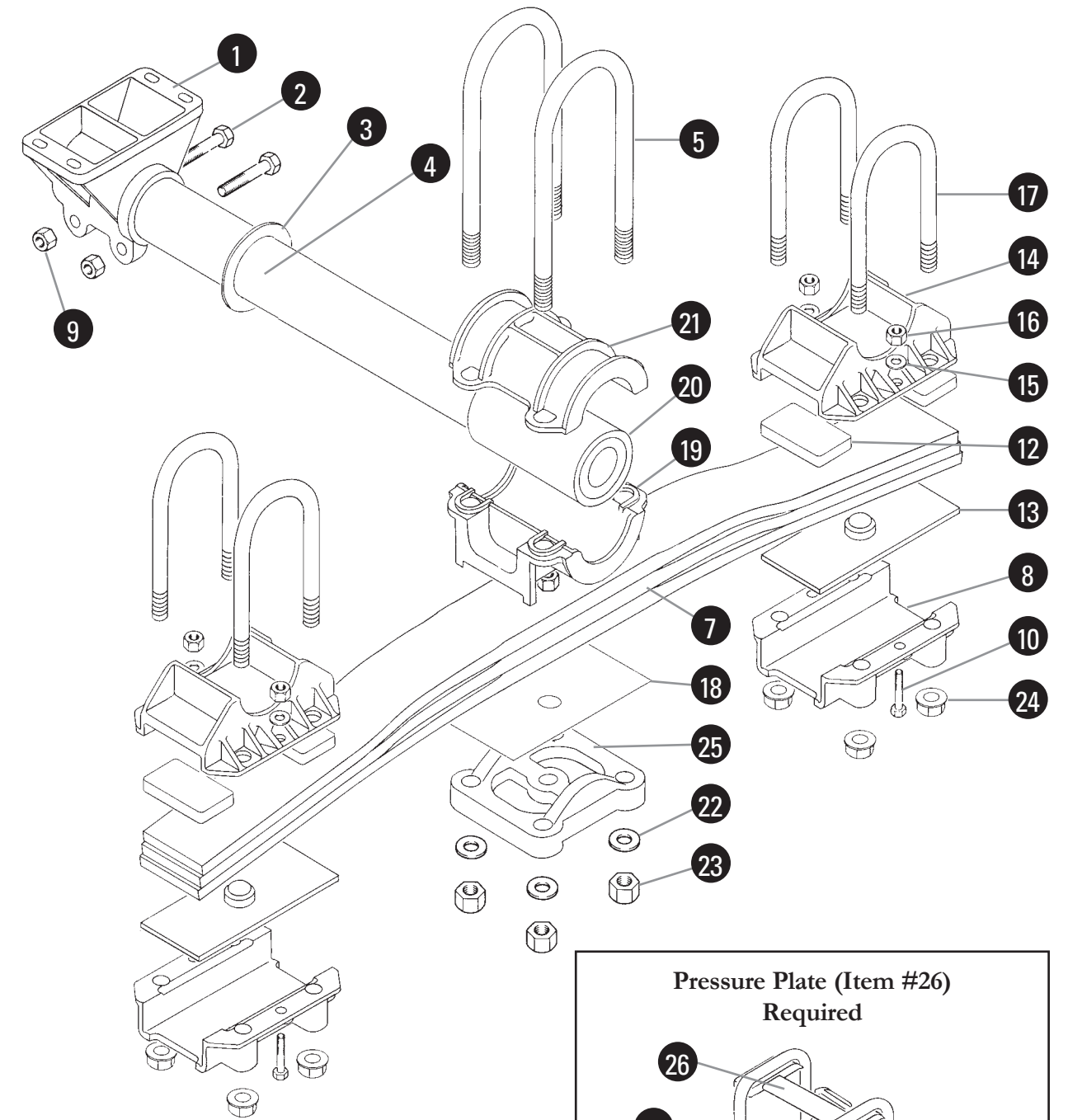
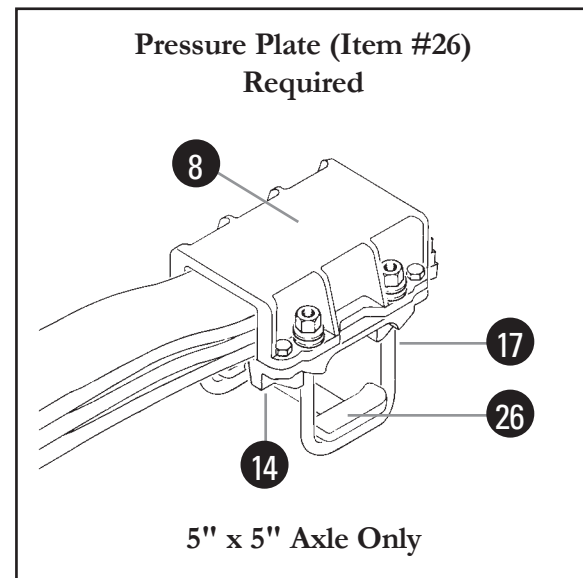
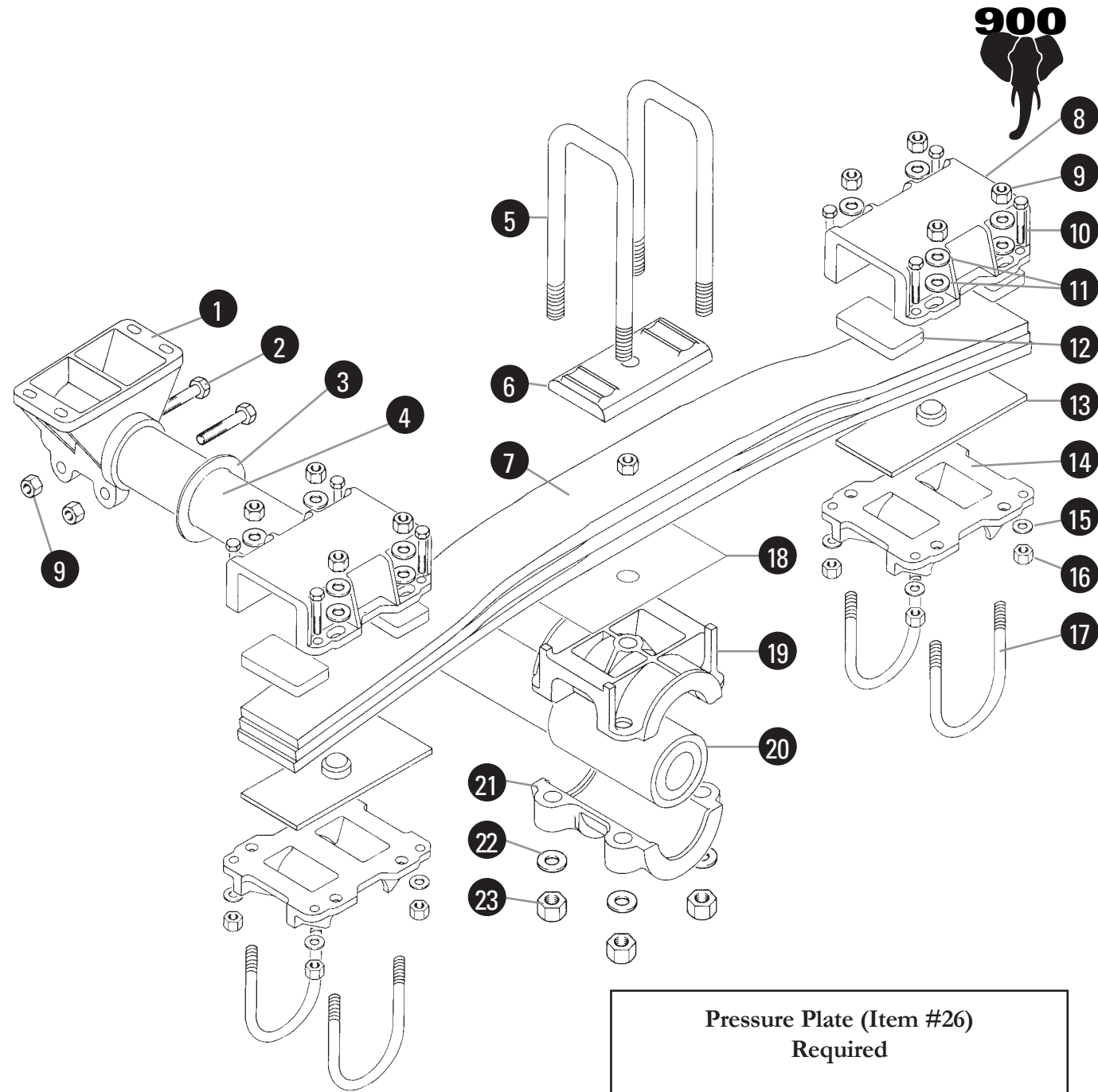

900 – 36, 42, 44, 50, 60 and 70,000

Chart A – Trunnion Hanger (Item #1)

	Trunnion Hanger Height			
	2 1/2"	4 1/2"	6 1/2"	8 1/2"
Part No.	850-01	10476-03	849-01	897-01

Chart B – Trunnion Tube (Item #4)

Unit Weight Capacity (lbs.)	Spring Centers/Trunnion Hanger Centers				
	38"/22.12"	36"/20.12"	44"/28.12"	42"/26.12"	41"/25.12"
36,000 - 44,000	893-01	893-04	893-07	893-09	893-11
50,000 - 70,000	893-02	893-05	893-08	893-10	893-12

Chart C – Trunnion U-Bolt (Item #5)

Unit Weight/Spring Capacity (lbs.)/Part No.	Trunnion Configuration			
	Overslung	Lgth.	Underslung	Lgth.
36,000/10054-00	9639-01	12 5/16"	835-02	13 3/4"
36,000/11151-00	9639-01	12 5/16"	835-02	13 3/4"
36,000/16258-01	9639-10	11"	835-01	12 3/8"
42,000/9997-00	9639-02	13 1/8"	835-03	14 5/8"
42,000/9998-00	9639-02	13 1/8"	835-03	14 5/8"
44,000/12258-01	9639-01	12 5/16"	835-02	13 3/4"
50,000/10055-00	9639-03	13 15/16"	835-04	15 3/8"
50,000/9999-00	9639-03	13 15/16"	835-04	15 3/8"
50,000/12258-01	9639-01	12 5/16"	835-02	13 3/4"
50,000/10000-00	9639-04	14 11/16"	835-06	16 1/8"
60,000/10001-00	9639-05	15 1/2"	835-05	17"
70,000/24967-01	9639-06	16 1/4"	835-08	18"

Chart E – Spring End Cap (Item #8)

Axle Size	Unit Weight Capacity (lbs.)	Axle Configuration	
		Overslung	Underslung
5" Rd. – 5" x 5" Sq.	36,000	10049-00	10050-02
	42-70,000	9937-00	9941-02
5 3/4" Rd. – 6" Rd.	36,000	10049-00	—
	42-70,000	9937-00	9942-02

Chart F – Spring Seat (Item #14)

Axle Size	Axle Configuration	
	Overslung	Underslung
5" Rd.	9934-02	9938-00
5" x 5" Sq.	9935-02	9939-00
5 3/4" Rd.	9936-03	9940-00
6" Rd.	9936-04	9940-01

Chart G – Axle U-Bolt (Item #17)

Axle Size	Unit Weight Capacity (lbs.)	Axle Configuration			
		Overslung	Lgth.	Underslung	Lgth.
5" Rd.	36,000	10060-01	7"	10064-01	9 3/4"
	42-70,000	10060-01	7"	10064-02	10 1/2"
5" x 5" Sq.	36,000	10063-02	7 7/8"	10067-02	10 1/2"
	42-70,000	10063-02	7 7/8"	10067-03	11 1/8"
5 3/4" Rd.	36,000	10061-01	8"	10065-01	11 1/2"
	42-70,000	10061-01	8"	10065-01	11 1/2"
6" Rd.	36,000	10062-01	8"	10066-01	11 1/2"
	42-70,000	10062-01	8"	10066-01	11 1/2"

Pre-Installation

The 900 single point suspension is shipped assembled - except for the axle U-bolts, nuts and washers which are packaged separately. On each axle there is one adjustment plate factory welded, and one that is welded by the installer following axle alignment. Refer to the preceding pages for detailed component information, unit capacity, and mounting heights. Before beginning any installation procedures, the customer should read all installation instructions thoroughly.

Prior to installation check for interference between brake camshafts and suspension components. Recommended camshaft locations are as follows:

Fig. 1

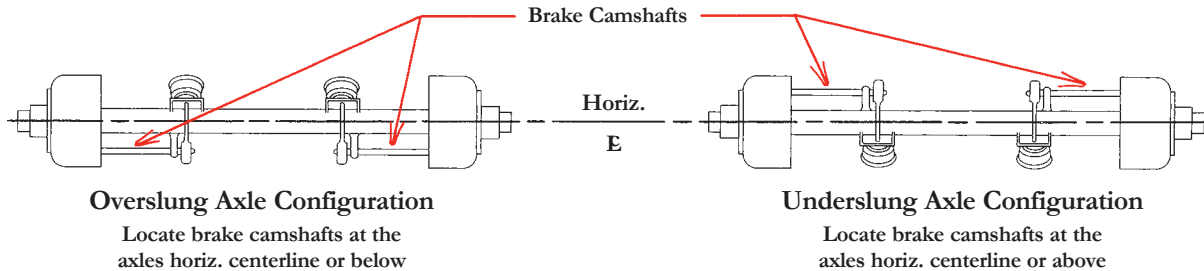

Inspect the suspension assembly to be certain that spring alignment has not been destroyed during shipment.

Set the suspension on the axles. Check to see that the springs are parallel to each other and perpendicular to the trunnion tube. See Fig. 2. Be sure the nuts on the trunnion hub U-bolts are torqued to specification.

Fig. 2

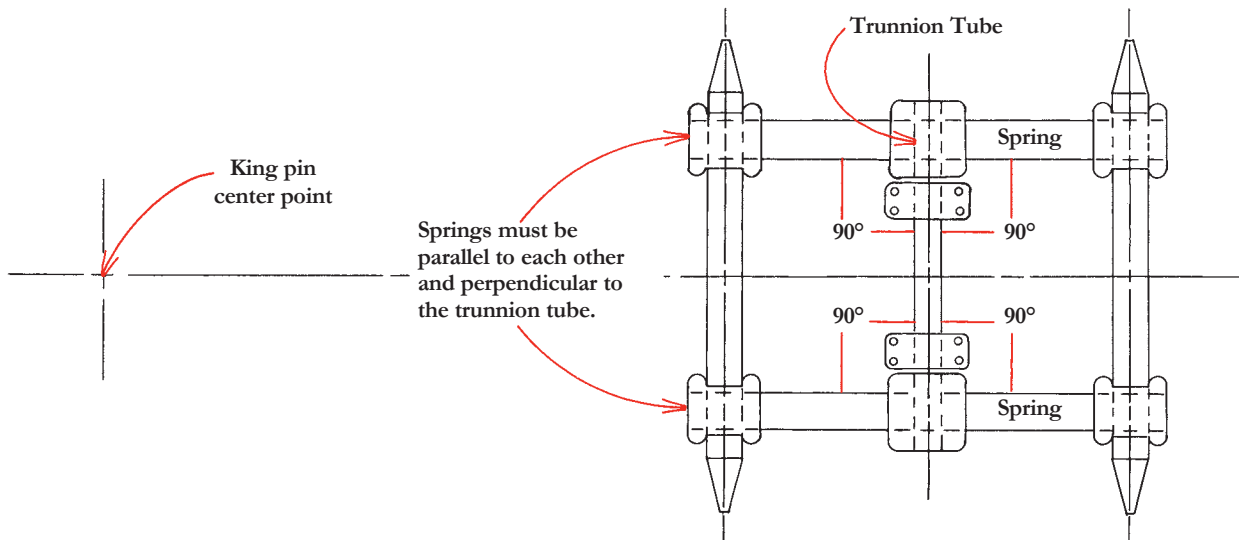

Axle Installation

1. With the axle camber up, locate the center of both axles by measuring between the brake flanges and marking the center.
2. Place the suspension on the axles, making certain that the axle seats are an equal distance from the center of the axle. All axle seats should measure the same distance from the brake flanges.
3. Align the camber marks on the top of the axle with the centerline of the axle seats. Be certain that all axle seats fit

the axle properly. If necessary, grind the axle seats to ensure that they fit properly, and are horizontal and parallel.

4. Tack-weld seats in place and recheck to make certain they are still level, parallel, and in the proper location and alignment.

Important: On underslung models, axle seats must be located beneath axles. See Fig. 3. Be certain that the camber marks are on top of the axle.

Fig. 3

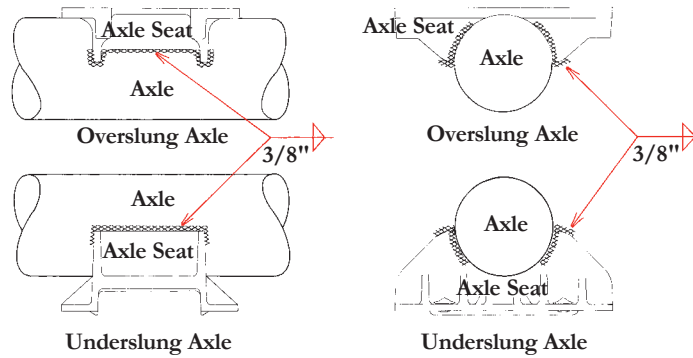

5. Check tire clearance with the suspension at this time. See Fig. 4.
6. Following the axle manufacturer's welding recommendations, weld the axle seats to the axle using 3/8" fillet welds on front and rear of the axle seats. See Fig. 3.

Caution: Do not attach welding ground clamps to U-bolts, springs or axles except to designated weld points. These parts should be protected from weld splatter.

7. Assemble axle U-bolts to spring end boxes, but do not tighten.

Fig. 4

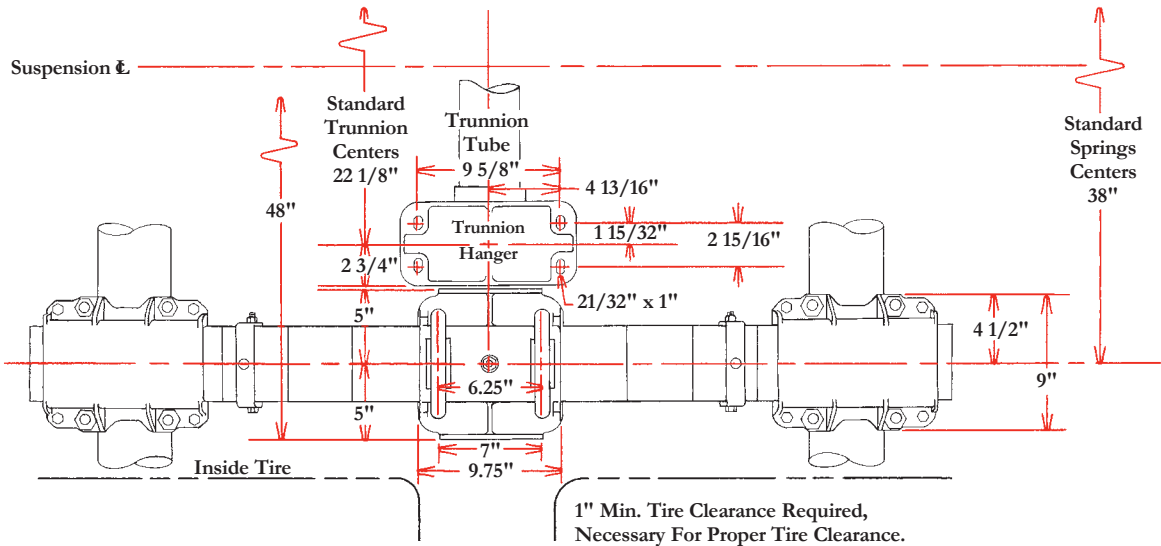

Preparing Trailer Frame For Mounting Tandem Assembly

Determine suspension location on the trailer frame by measuring from the king pin to outside of the frame at desired location and marking each side at the suspension's centerline. The frame should now be prepared for mounting of the suspension in one of the following three ways:

1. Use of the optional Hutch mounting brackets (Part #16793-01). Two each are required. See Fig. A on Page 3.

Note: Additional bracing (furnished by the installer) connecting one mounting bracket with the other is recommended. See Fig. 5 on Page 11.

2. Fabrication of your own mounting bracket.
3. Bolting directly to the frame.

Note: When any of the aforementioned methods of mounting the suspension are utilized, a "minimum dimension" must be maintained between the trunnion tube centerline and the top of the suspension components. See Fig. 5. This minimum dimension is tabulated in Chart H.

Chart H

Model	Number of Spring Leaves	Minimum Dimension	
		Overslung Trunnion	Underslung Trunnion
900-36	2	9"	4 1/2"
900-36	5	10 1/2"	4 1/2"
900-42	6	11 1/4"	4 1/2"
900-44	3	10"	4 1/2"

Model	Number of Spring Leaves	Minimum Dimension	
		Overslung Trunnion	Underslung Trunnion
900-50	3	10"	4 1/2"
900-50	7	12"	4 1/2"
900-50	8	12 3/4"	4 1/2"
900-60	9	13 1/2"	4 1/2"
900-70	10	14 1/4"	4 1/2"

Installation Using Hutchens Mounting Brackets (Part #16793-01)

Fig. 5

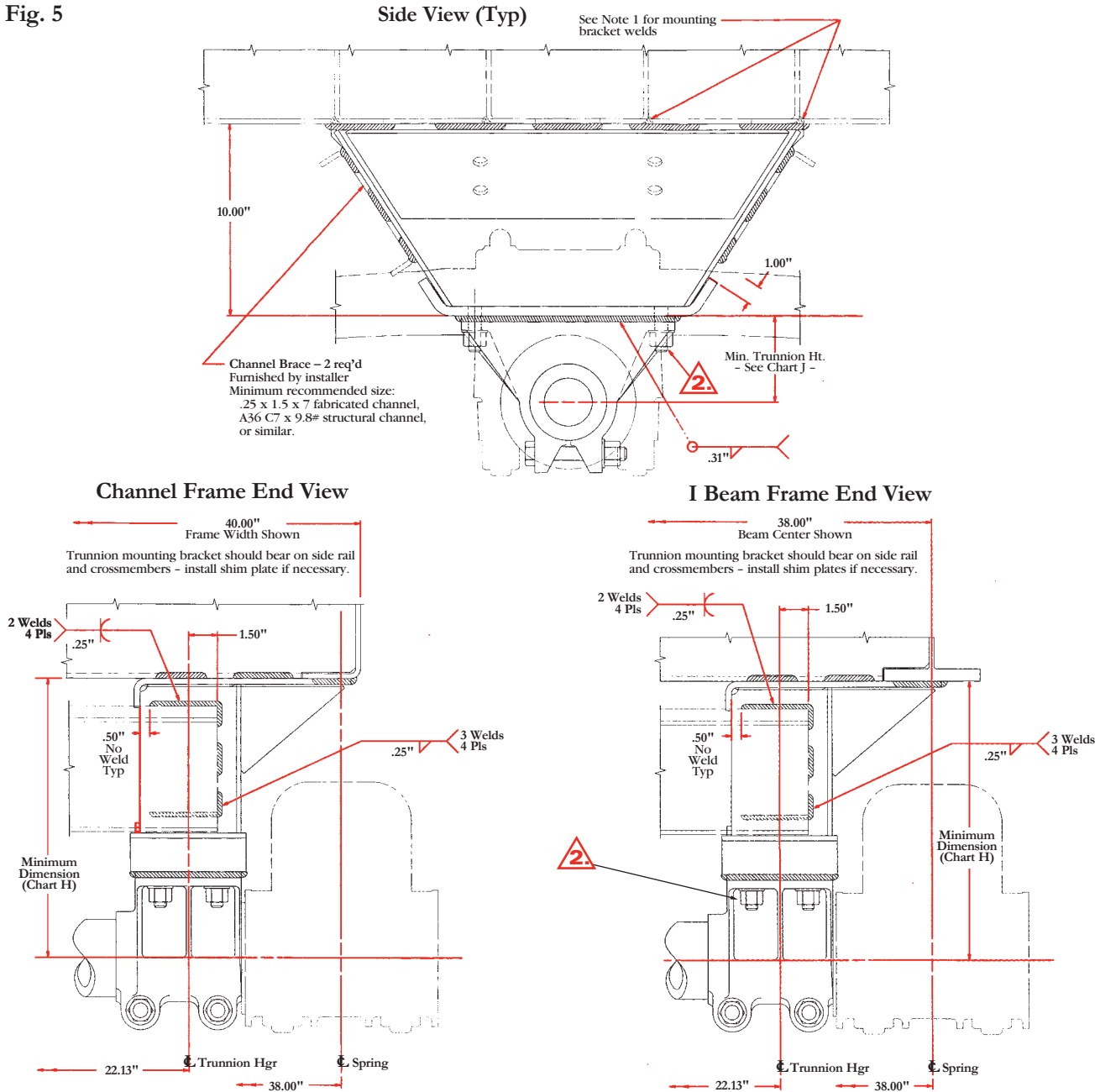

Chart J

Number of Spring Leaves	2	3	5	6	7	8	9	10
Min. Trunnion Hanger Ht.	2.50	4.50	4.50	4.50	6.50	6.50	6.50	8.50

Note:

1. a) The upper trailer structure shown is intended to be a generic representation of a typical installation, and is not intended to be a detailed recommendation for a fabrication of a trailer subframe.
- b) The welds attaching the mounting bracket to the subframe will be determined by the configuration of the structure, and are the responsibility of the trailer manufacturer.

- c) As a general recommendation, the frame bracket should be welded to the trailer structure with either a solid weld or skip welds that cover at least 60% of the mounting bracket perimeter. Do not weld within 1/2" of any raw edges of the trailer main rails or crossmembers. Welding should be in accordance with AWS E70XX procedures or equivalent.

2. Mounting bracket bolts are to be furnished by installer. For one piece trunnion hangers use 5/8" Grade 5 or better bolts and Grade B or better nuts. For two piece trunnion hangers use 3/4" Grade 8 bolts and Grade C nuts.

Mounting Tandem Assembly To Trailer

1. Attach trunnion hanger to mounting bracket or trailer frame. Do not tighten bolts.

2. Align the trunnion tube with the king pin. Dimensions T_1 and T_2 must be equal. See Fig. 6.

Fig. 6

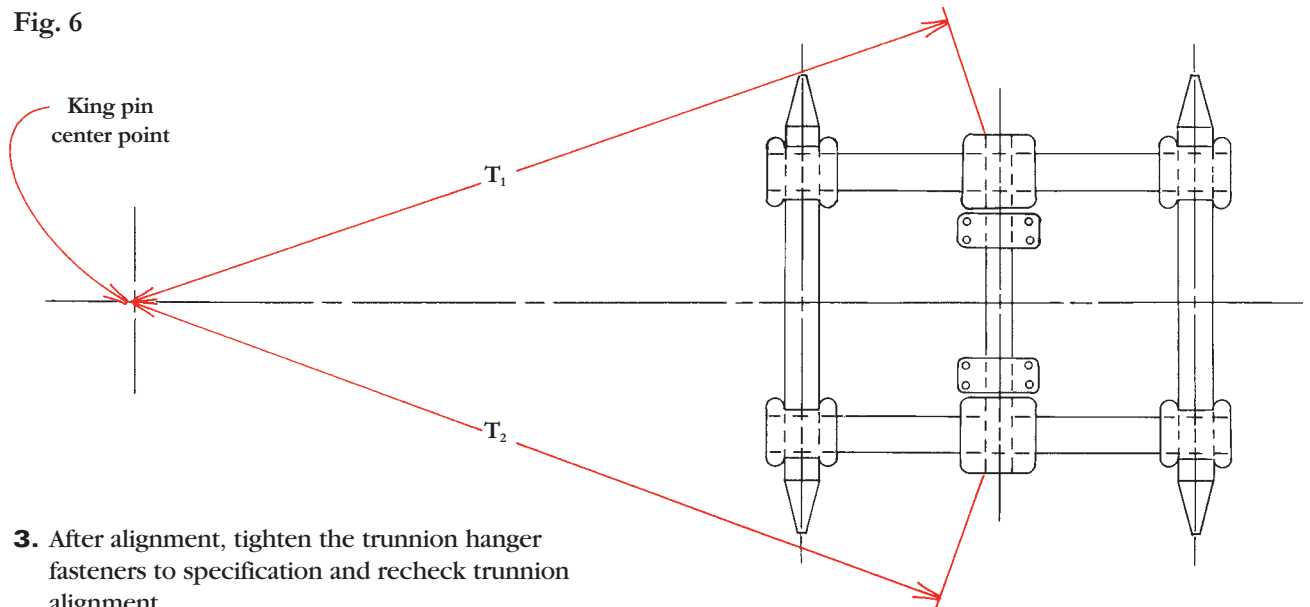

3. After alignment, tighten the trunnion hanger fasteners to specification and recheck trunnion alignment.

4. When the trunnion tube has been aligned and the trunnion hanger bolts have been torqued, weld the

trunnion hanger all around to the mounting bracket or trailer frame and frame member. See Fig. 7.

Fig. 7

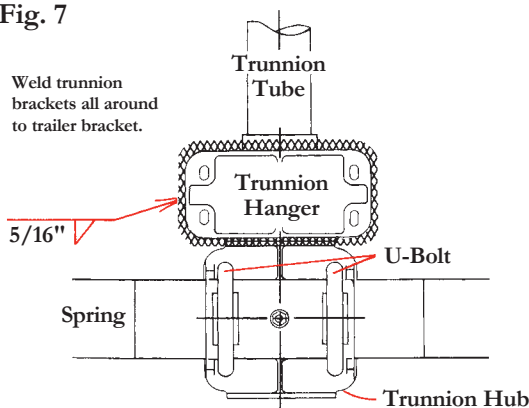
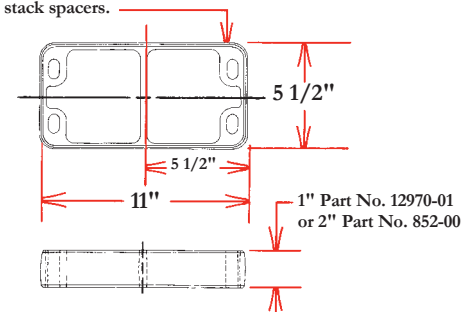

Fig. 8

When using the 852-00 or 12970-01 spacer, insert spacer between hanger casting and extension bracket and weld solidly top and bottom. Do not stack spacers.



Note: To achieve non-standard trunnion hanger heights, a spacer is sometimes used atop the trunnion hanger. See Fig. 8. When using a spacer, it must be solidly welded to both the trunnion hanger and mounting bracket or frame. Do not stack spacers.

5. After the trunnion hangers have been attached to the trailer frame, tighten the 3/4" clamp fasteners to specification. See Fig. 9.

Fig. 9

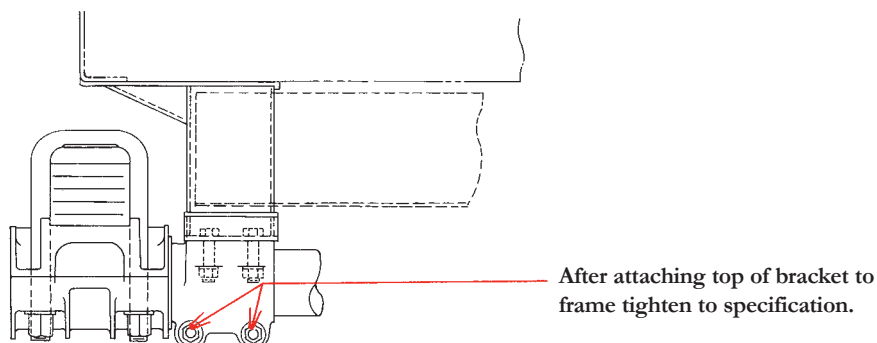

Bump-Outs

When rubber bushings are utilized in the trunnion connection, the maximum oscillation at the trunnion hub should not exceed 15° above or below horizontal. See Fig. 10.

Spring end boxes are designed to accept bump-outs or stops, which the installer should provide to assure tire clearance or to limit oscillation - whichever becomes critical first.

Fig. 10

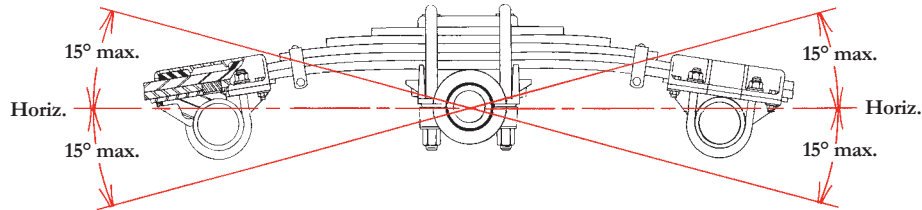

Axle Alignment

After the suspension has been installed under the trailer, the axles should be properly aligned in relation to the trailer king pin in the following manner: Measure the distance from the king pin to the centerline of the spindles on the front axle. As noted in Fig. 11, dimensions A and B must be equal within 1/8 of an inch. After aligning the front axle, tighten the U-bolts and end clamp bolts to specification on that axle only. Next, align

the rear axle with the front axle. As noted in Fig. 11, dimensions C and D must be equal within 1/16 of an inch. After aligning the rear axle with the front axle, tighten the U-bolts and end clamp bolts on the rear axle. Refer to TTMA RP No. 71-05 (Trailer Axle Alignment) for more detail.

Fig. 11

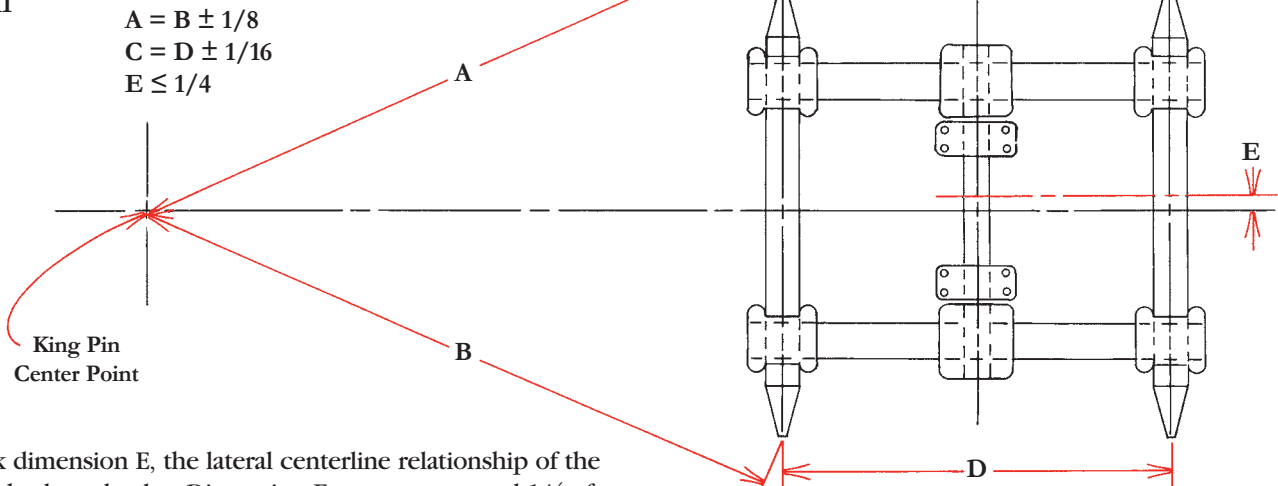

Check dimension E, the lateral centerline relationship of the trailer body and axles. Dimension E must not exceed 1/4 of an inch. At this time, recheck the alignment of the front axle with the king pin, and the rear axle with the front axle. After

alignment has been accomplished, tighten the U-bolts and nuts to specification.

Adjustment Plate Welding

On each axle there is one adjustment plate that is welded at the factory and one that is not.

After alignment has been completed, weld the unwelded alignment plate exactly like the one that has been welded at the factory. See Fig. 12.

Fig. 12

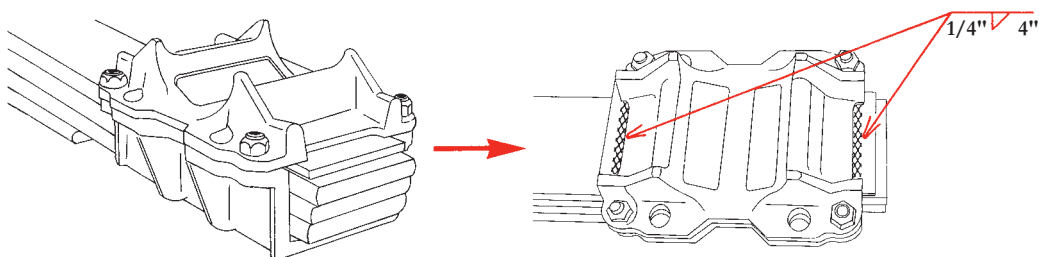

CAUTION – These adjustment plates **MUST BE WELDED BEFORE** operating the trailer.

Check all fasteners (U-bolts, end cap, trunnion hub, etc.) to make sure they are torqued to specification. Torque for all fasteners should be checked after an initial break-in period, and periodically thereafter. See Decal Note on Page 14.

Numerical Listing of Parts

Part No.	Description	Pg. #	Part No.	Description	Pg. #
814-00	Rubber Pad - Plain	5	9936-04	Spring Seat - Adj., 6 RD, OS	8
817-00	Washer - 1/8 x 13/16 ID x 1 1/2 OD	5	9937-00	Spring End Cap - OS	8
820-00	Spring Clamp Plate	5	9938-00	Spring Seat - 5 RD, US	8
835-01	U-Bolt - 1.067 DIA, 5 7/8 RD x 12 3/8	8	9939-00	Spring Seat - 5 SQ, US	8
835-02	U-Bolt - 1.067 DIA, 5 7/8 RD x 13 3/4	8	9940-00	Spring Seat - 5 3/4 RD, US	8
835-03	U-Bolt - 1.067 DIA, 5 7/8 RD x 14 5/8	8	9940-01	Spring Seat - 6 RD, US	8
835-04	U-Bolt - 1.067 DIA, 5 7/8 RD x 15 3/8	8	9941-02	Spring End Cap - Adj., 5 RD & 5 SQ, US	8
835-05	U-Bolt - 1.067 DIA, 5 7/8 RD x 17	8	9942-02	Spring End Cap - Adj., 5 3/4 RD & 6 RD, US	8
835-06	U-Bolt - 1.067 DIA, 5 7/8 RD 16 1/8	8	9997-00	Spring Assembly - 6 Leaf, 42,000 LB, 48 AC	4, 5, 8
835-08	U-Bolt - 1.067 DIA, 5 7/8 RD x 18	8	9998-00	Spring Assembly - 6 Leaf, 42,000 LB, 50.5 AC	4, 5, 8
836-00	Hex Nut - 1 1/8 - 12 UNF, 1 1/2 HI	5	9999-00	Spring Assembly - 7 Leaf, 50,000 LB, 50.5 AC	4, 5, 8
837-00	Washer - 1/8 x 1 1/4 ID x 2 1/4 OD	5	10000-00	Spring Assembly - 8 Leaf, 50,000 LB, 54 AC	4, 5, 8
841-00	Hex Nut - Self Locking, 3/4 - 16 UNF	5	10001-00	Spring Assembly - 9 Leaf, 60,000 LB, 54 AC	4, 5, 8
849-01	Trunnion Hgr. - Cast, 6 1/2 HI, 11 LG	8	10049-00	Spring End Cap - OS, 36,000 LB	8
850-01	Trunnion Hgr. - Cast, 2 1/2 HI, 11 LG	8	10050-02	Spring End Cap - Adj., US, 36,000 LB	8
852-00	Spacer - Trunn Hgr, 2 High, 11 LG	12	10054-00	Spring Assembly - 5 Leaf, 36,000 LB, 48 AC	4, 5, 8
890-00	Rubber Bushing - Trunnion Hub	5	10055-00	Spring Assembly - 7 Leaf, 50,000 LB, US	4, 5, 8
891-00	Trunnion Hub - Upper Half, Cast	5	10060-01	U-Bolt - 0.706 DIA, 5 RD x 7	8
892-00	Trunnion Hub - Lower Half, Cast	5	10061-01	U-Bolt - 0.706 DIA, 5 3/4 RD x 8	8
893-01	Trunnion Tube - 1/2 Wall, 48 LG	8	10062-01	U-Bolt - 0.706 DIA, 6 RD x 8	8
893-02	Trunnion Tube - 3/4 Wall, 48 LG	8	10063-02	U-Bolt - 0.706 DIA, 5 SQ x 7 7/8	8
893-04	Trunnion Tube - 1/2 Wall, 46 LG	8	10064-01	U-Bolt - 0.949 DIA, 5 RD x 9 3/4	8
893-05	Trunnion Tube - 3/4 Wall, 46 LG	8	10064-02	U-Bolt - 0.949 DIA, 5 RD x 10 1/2	8
893-07	Trunnion Tube - 1/2 Wall, 54 LG	8	10065-01	U-Bolt - 0.949 DIA, 5 3/4 RD x 11 1/2	8
893-08	Trunnion Tube - 3/4 Wall, 54 LG	8	10066-01	U-Bolt - 0.949 DIA, 6 RD x 11 1/2	8
893-09	Trunnion Tube - 1/2 Wall, 52 LG	8	10067-02	U-Bolt - 0.949 DIA, 5 SQ x 10 1/2	8
893-10	Trunnion Tube - 3/4 Wall, 52 LG	8	10067-03	U-Bolt - 0.949 DIA, 5 SQ x 11 1/8	8
893-11	Trunnion Tube - 1/2 Wall, 51 LG	8	10273-00	Washer - 1/8 x 21/32 ID x 1 5/16 OD	5
893-12	Trunnion Tube - 3/4 Wall, 51 LG	8	10376-00	Hex Bolt - 3/4 - 16 UNF x 4 1/2 LG, GR 5	5
895-00	Washer - 7 GA x 4 1/32 ID x 5 3/4 OD	5	10476-03	Trunnion Hgr. - Cast, 4 1/2 HI	8
897-01	Trunnion Hgr. - Cast 8 1/2 HI, 11 LG	8	10488-00	Pressure Plate - Cast, 5 SQ	5
898-00	Trunnion Hub - Lower Half, Cast	5	10562-00	Flange Locknut - 1-14 UNS, GRF, Phos & Oil	5
9293-00	Hex Bolt - 5/8 - 18 UNF x 2, GR 5	5	10608-00	Plate - Adj.	5
9639-01	U-Bolt - 1.067 DIA, 5 1/8 SQ, 12 5/16	8	11151-00	Spring Assembly - 5 Leaf, 36,000 LB, 50.5 AC	4, 5, 8
9639-02	U-Bolt - 1.067 DIA, 5 1/8 SQ, 13 1/8	8	11513-03	Hex Locknut - 5/8 - 18 UNF, 28, GRC	5
9639-03	U-Bolt - 1.067 DIA, 5 1/8 SQ, 13 15/16	8	12258-01	Spring Assembly - 3 Leaf	4, 5, 8
9639-04	U-Bolt - 1.067 DIA, 5 1/8 SQ, 14 11/16	8	12919-01	Galvanized Liner - .040 x 4.75 x 10.00	5
9639-05	U-Bolt - 1.067 DIA, 5 1/8 SQ, 15 1/2	8	12970-01	Spacer - Trunn Hgr, 1 High, 11 LG	12
9639-06	U-Bolt - 1.067 DIA, 5 1/8 SQ, 16 1/4	8	16087-01	Decal - 900 Series	14
9639-10	U-Bolt - 1.067 DIA, 5 1/8 SQ, 11	8	16258-01	Spring Assembly - 2 Leaf	4, 5, 8
9640-00	Top Plate - Cast, SQ U-Bolt	5	16793-01	Mounting Bracket - H900, 10.00 HI	3, 11
9934-02	Spring Seat - Adj., 5 RD, OS	8	23276-01	Trunnion Bushing - Free Oscillating,	5
9935-02	Spring Seat - Adj., 5 SQ, OS	8		5% Oil Filled PUR, 9.00 LG	
9936-03	Spring Seat - Adj., 5 3/4 RD, OS	8	24967-01	Spring Assembly - 10 Leaf, 70,000 LB, 54 AC	4, 5, 8

Important: Warning Decal Note

When the installation of your "Hutch" single point suspension is complete and the trailer has been painted, a torque requirement decal (Part No. 16087-01) must be installed in plain view on the road side of the trailer immediately above the suspension. It is essential that the correct decal is in plain view on each trailer. Decals are shipped with the suspension. If decals are not received, or if for any reason additional decals are wanted, contact our Customer Service Department at (800) 654-8824 or fax (417) 862-2317 and decals will be shipped promptly at no charge.

WARNING

SAFETY ALERT! (1) FOLLOW ALL TORQUE REQUIREMENTS. (2) DO NOT USE ANY COMPONENT WITH VISIBLY WORN OR DAMAGED THREADS. FAILURE TO FOLLOW THESE SAFETY ALERTS CAN LEAD TO LOSS OF VEHICLE CONTROL, PROPERTY DAMAGE, SERIOUS PERSONAL INJURY OR DEATH.

Hutchens Suspension Torque Requirements – 900/440 Series (Decal Part Number 16087-01 Rev. E)

After an initial break in period, approximately 1000 miles, and at least every 4 months periodically thereafter, ALL bolts and nuts should be checked to insure that recommended torque values are being maintained.

Oil torque values listed are for new fasteners with lubricated threads. It is recommended that new installations be performed with oiled fasteners. For dry threads which have been in service, use the higher torque values which are noted below.

	OILED	DRY
1 1/8-12 UNF	670 lb-ft	880 lb-ft
1-14 UNF	540 lb-ft	730 lb-ft
7/8-14 UNF	500 lb-ft	670 lb-ft
3/4-16 UNF	220 lb-ft	300 lb-ft
5/8-18 UNF	130 lb-ft	180 lb-ft

Hutchens Industries, Inc., P.O. Box 1427, Springfield, Missouri 65801-1427 Toll Free 1 (800) 654-8824



Advancing the Practical Application of Suspension Technology

Springfield, MO ■ (800) 654-8824 ■ (417) 862-5012
Fax (417) 862-2317 ■ www.hutchensindustries.com