

INSTALLATION AND OPERATION MANUAL

SUSPENSION SYSTEM

**SINGLE
POINT
SERIES**

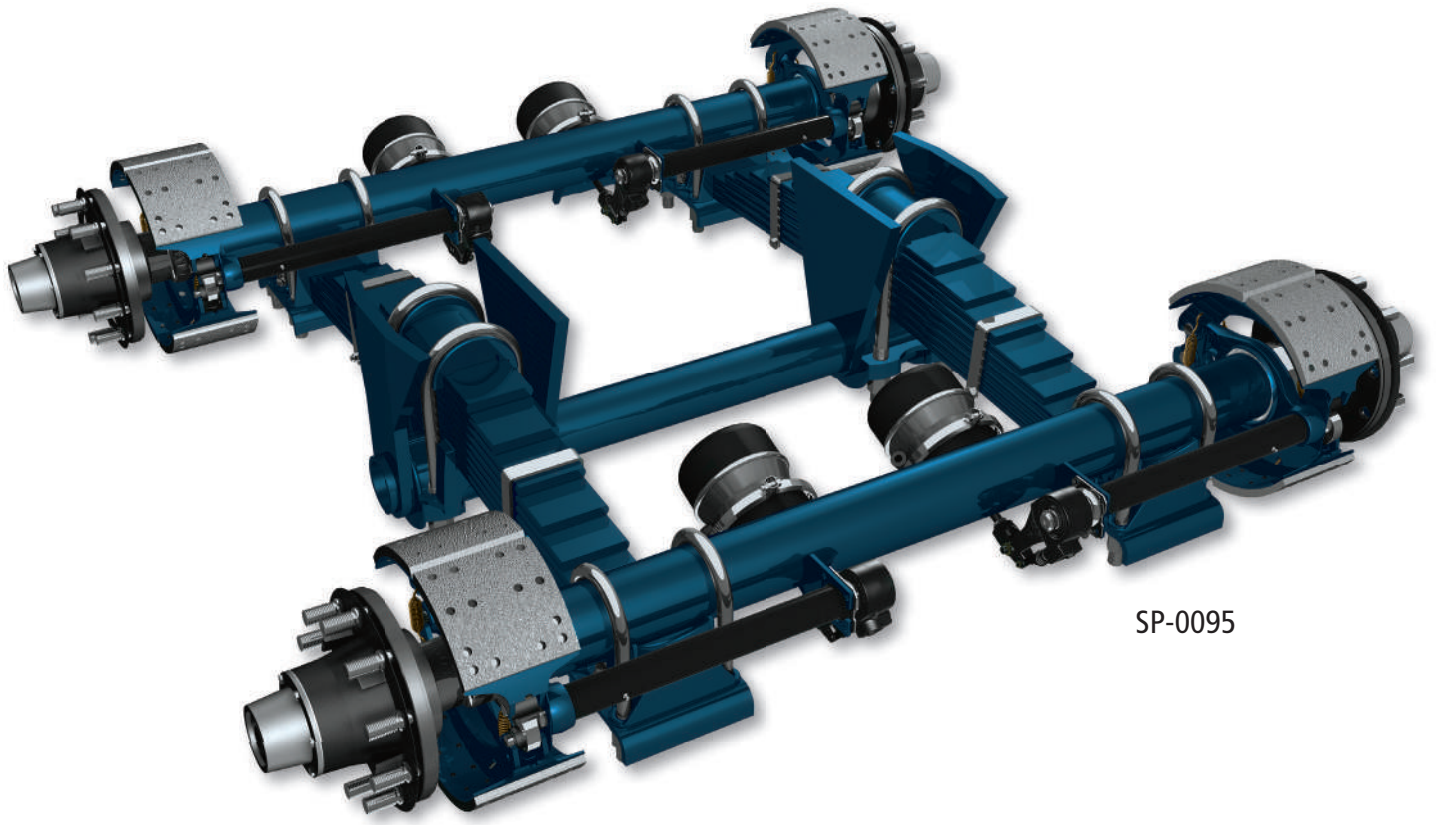

SP-0095

Delivering Suspension Solutions



For more information, call 800.445.0736

SP Series

Two-Spring Suspension
Subject: Installation and Operation Literature
Number: WCL03B03B



Table of Contents

Introduction	
Defective or Damaged Components	1
Installer Responsibility	1
Before You Begin	2
Safety Explanations	2
Cautions & Warnings	2
Identifying Your Model	3
Identification Plate	3
Parts List	3
TS Single Point	4
SM Single Point	6
SMR PAR Single Point	8
US Single Point	10
SMUS Single Point	12
PPSM Single Point With Heavy Duty End Caps	14
TSR Single Point	16
USR Single Point	18
SLIDE PAD OPTION.....	20
Installation	20
Slide Pad Identification and special instructions	22
Prior to Installing the SP-Series Suspension	23
Installing the Axles	24
Slide Pad Specific Prior to Installing & installing the Axles (includes weld instructions).....	25
Preparing the Trailer Frame	27
Assembling Tandem To Trailer	28
Axle Alignment	29
Weld Procedure	30
Slide Pad Specific Weld Procedure	30
Torque Requirements	32
Capscrew/Bolt (Grade 8 UNF Torque Requirements)	32
U-Bolt Torque Instructions	32
U-Bolt (Non-Plated Clean Lubricated Thread) Torque Requirements	32
Re-Torquing Guidelines	32
Notes	33

Literature # W&C136
REV 5/3/2011

WCL3B03A

Watson & Chalin Manufacturing, the Watson & Chalin Logo, and all other product or service names are registered trademarks of Watson & Chalin Manufacturing, Inc. Copyright 2010 Watson & Chalin Manufacturing, Inc., as an unpublished work. All rights reserved.

Watson & Chalin Manufacturing, Inc.
725 E. University, McKinney, TX. 75069 • 1.800.445.0736
www.watsonsuspensions.com

SP Series

Introduction

This publication is to acquaint and assist you in installing and operating the Watson & Chalin SP Series suspension product line and is intended for use only with this product line. This manual includes installation and operating information.:

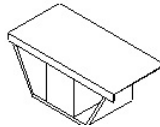

Single Point Pedestal Mount	Single Point Straddle Mount
HDTS	HDSM
LWTS	LWSM
HDUS	HDSMUS
LWUS	LWSMUS
HDTSR	HDSMR
LWTSR	LWSMR
HDUSR	PPSM
LWUSR	SMRPAR

TS Series Drawing #SP-0071

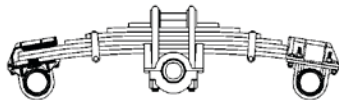

SM Series Drawing #SP-0066



US Series Drawing #SP-0072

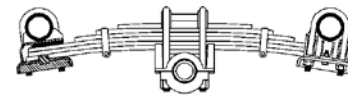

SMUS Series Drawing #SP-0095

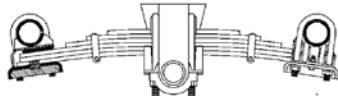

TSR Series Drawing #SP-0160

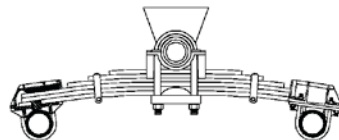

SMR Series Drawing #SP-0091

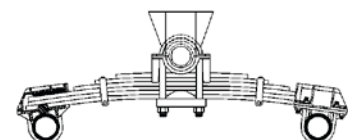

USR Series Drawing #SP-0234

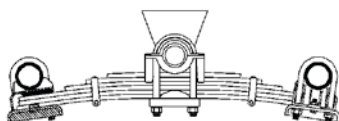

PPSM Series Drawing #SP-0074

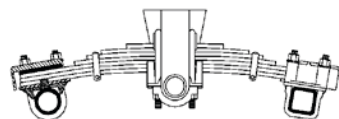

PPSMR Series Drawing #SP-0091

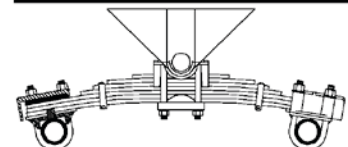

SP Series

Watson & Chalin reserves the right to change its products or manuals at any time. Contact Watson & Chalin at 1.800.445.0736 for information on recent changes to products.

This manual should be used in conjunction with corresponding drawings that come with Watson & Chalin suspensions upon delivery.

Any changes to the trailer frame must be approved by the manufacturer before the changes are done. Cutting or altering the vehicle's frame is normally not permitted and affects the warranty coverage.

Important

The entire manual must be read and understood before proceeding with installation or service of any components.

Defective or Damaged Components

Should be returned to Watson & Chalin with a pre-arranged Returned Goods Authorization (RGA) number through the Warranty Department. The damaged or defective component may then be replaced; when in compliance with warranty conditions. Contact Watson & Chalin at 1.800.445.0736 for information.

Installer Responsibility

The installer of the suspension system must:

- Ensure that the trailer will function properly with the new suspension.
- Ensure that beams, crossmembers and suspension attachment are adequate for the suspension.
- Determine the correct location of the suspension to provide the proper load distribution as to not exceed the rated capacity of the components involved.
- Ensure the installation of the correct brake system components to guarantee proper braking performance.
- Ensure axles are welded properly to suspension if purchased separate or anytime axles are not purchased pre-welded by Watson & Chalin

SP Series

Before You Begin

Before you begin to install the Watson & Chalin suspension system, you must:

- Check your company specifications on suspension systems to be sure that the correct suspension system was chosen for the trailer.
- Verify the frame width is within the allowable mounting range of the suspension and that the trailer crossmembers are correctly positioned.
- Mark the location of the suspension and check for interferences with existing components.

Safety Explanations

Watson & Chalin uses the following types of notes to warn against possible safety problems and to give information that helps to prevent damage to equipment.

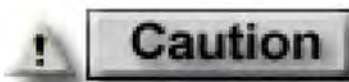

A caution indicates hazards or unsafe practices which could result in damage to equipment or minor personal injury if the procedure is not followed exactly.



A WARNING INDICATES HAZARDS OR UNSAFE PRACTICES WHICH COULD RESULT IN SEVERE PERSONAL INJURY OR DEATH IF THE PROCEDURE IS NOT FOLLOWED EXACTLY.

Important

An important message which indicates that the procedure should be followed exactly.

All safety statements should be read carefully to prevent bodily injury, to assure that parts are assembled properly, and to retain the manufacturer's warranty.

Cautions & Warnings



**PROPER AXLE ATTACHMENT WELDS ARE REQUIRED FOR SAFE OPERATION OF THE VEHICLE.
NO ALTERATION OF ANY WATSON & CHALIN SUSPENSION COMPONENTS IS PERMITTED WITHOUT PROPER AUTHORIZATION FROM QUALIFIED WATSON & CHALIN PERSONNEL.**

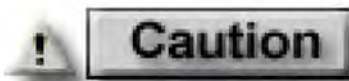

**No welding of any suspension components is permitted except when specified by Watson & Chalin.
Do not weld to Springs**

SP Series

Important

Any deviation from the installation instructions must be approved in writing by Watson & Chalin

Identifying Your Model

It is important that you know what model number has been assigned to your assembly in case you ever need to contact Watson & Chalin.

Identification Plate

Each assembly has an identification plate located near the spring cap of the suspension (see below), on the driver's side of the vehicle, which identifies it. The plate includes the model number, serial number, and capacity in pounds for the assembly. It is important to record the model number for future reference.

Figure 1: Identification Plate



Parts List

The following section shows exploded views of various SP Series suspensions and corresponding parts lists that describe each of the numbered parts. Some Single Point series models also have an additional table that corresponds to the main parts list. The exploded views of the Single Point, the parts lists and the corresponding tables are intended to help you identify parts and part numbers that may need to be replaced.

SP Series

Figure 2: Exploded View–TS Single Point (HDTS)

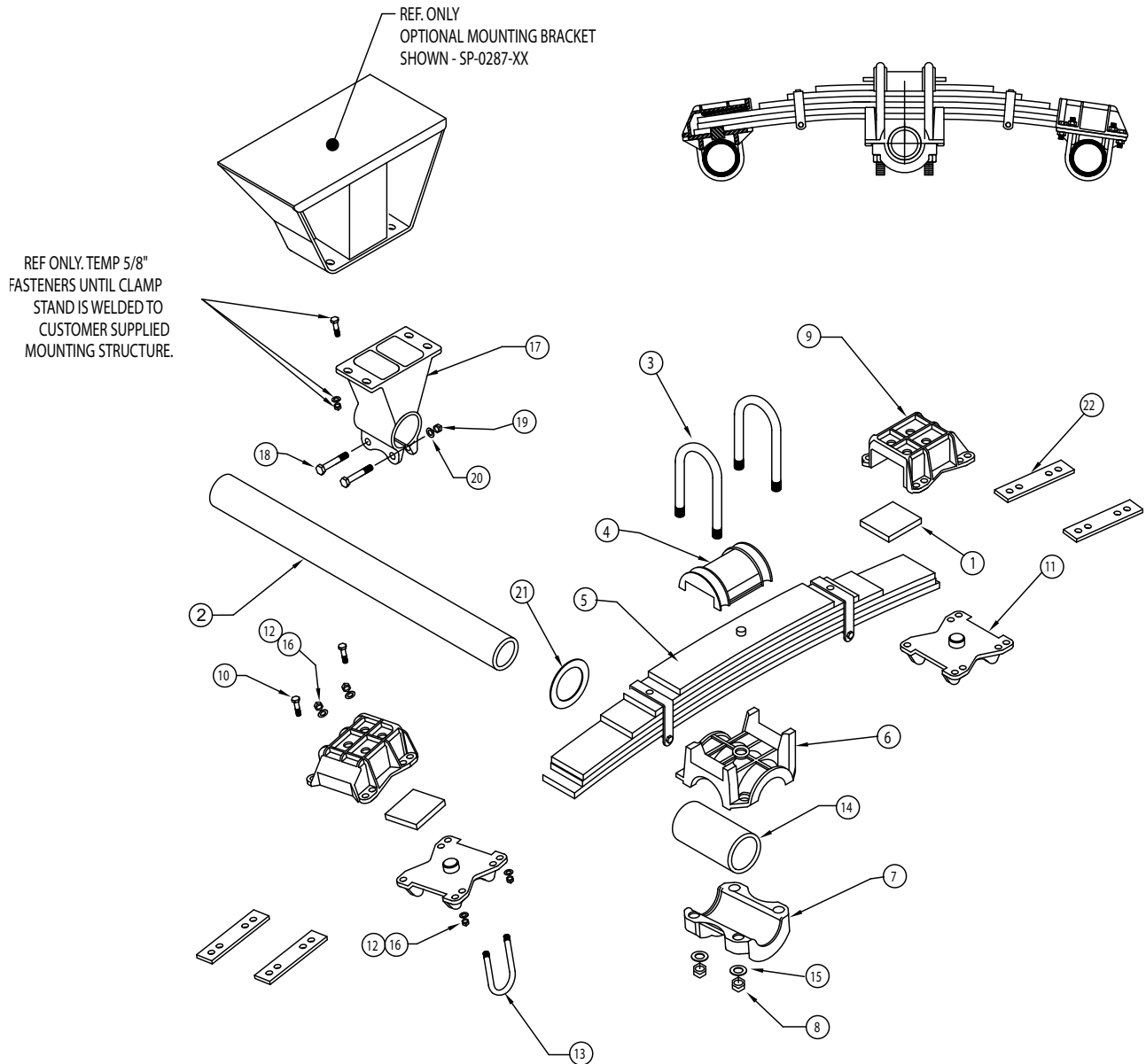

Table 2: TS Single Point Parts List

Item #	Description	Quantity	Part #
1	Polyurethane Pad	4	SP-0193
2	Trunnion Tube	1	Part number depends on spring centers
3	U-bolt	4	See Chart 2

SP Series

Item #	Description	Quantity	Part #
4	Spring Cap	2	SP-0003
5	Spring	2	See Chart 2
6	Trunnion Cap/Spring Seat	2	SP-0001
7	Trunnion Cap	2	SP-0006
8	High Nut 1.125 UNF. Grade 8	8	10003
9	Cap Spring End	4	See Chart 2
10	Capscrew .625 X 2.00 UNF. Grade 8	16	10034
11	Axle Seat/Spring Pin Assembly	4	See Chart 2
12	Locknut .625 UNF. Grade 8	32	10029
13	U-bolt	8	See Chart 2
14	Polyurethane Bushing	2	SP-0192
15	Washer, 1.125 Hardened	8	10045
16	Washer, .625 Hardened	32	10032
17	Trunnion Clamp Stand	2	See Chart 2A
18	Capscrew .75 UNF. 5.0 Long Grade 8	4	10033
19	Locknut, .75 UNF Grade C	4	10028
20	Flat Washer, .75 Hardened	4	10043
21	Washer Flat 4.12X6.00X.12	2	SP-0038
22	Shim Spacer .25" End Cap	8	See Chart 2

Chart 1

Model	Item 3	Item 5	Item 9	Item 11		Item 13		Item 22
				5" Rd Axle	5" Sq Axle	5" Rd Axle	5" Sq Axle	
HDTS44	SP-0023	SP-0056	SP-0007	SP-0036	SP-0048	SP-0021	SP-0052	N/A
HDTS50	SP-0023	SP-0057	SP-0007	SP-0036	SP-0048	SP-0021	SP-0052	N/A
HDTS60	SP-0022	SP-0243	SP-0007	SP-0036	SP-0048	SP-0021	SP-0052	N/A
LWTS44	SP-0023	SP-0058-01	SP-0016	SP-0036	SP-0048	SP-0021	SP-0052	N/A
LWTS50	SP-0023	SP-0061	SP-0016	SP-0036	SP-0048	SP-0021	SP-0052	SP-0083
LWTSPAR50	SP-0249	SP-0056	SP-0007	SP-0036	SP-0048	SP-0021	SP-0052	SP-0083
HDTS70	SP-0187	SP-0070	SP-0007	SP-0036	SP-0048	SP-0021	SP-0052	N/A
HDTS70-60AC	SP-0187	-	SP-0007	SP-0036	SP-0048	SP-0021	SP-0052	N/A

Chart 2A

Item 17	
Clamp Stand Height	Part No.
8.5"	SP-0009
6.5"	SP-0010
4.5"	SP-0011
2.5"	SP-0012

SP Series

Figure 3: Exploded View–SM Single Point

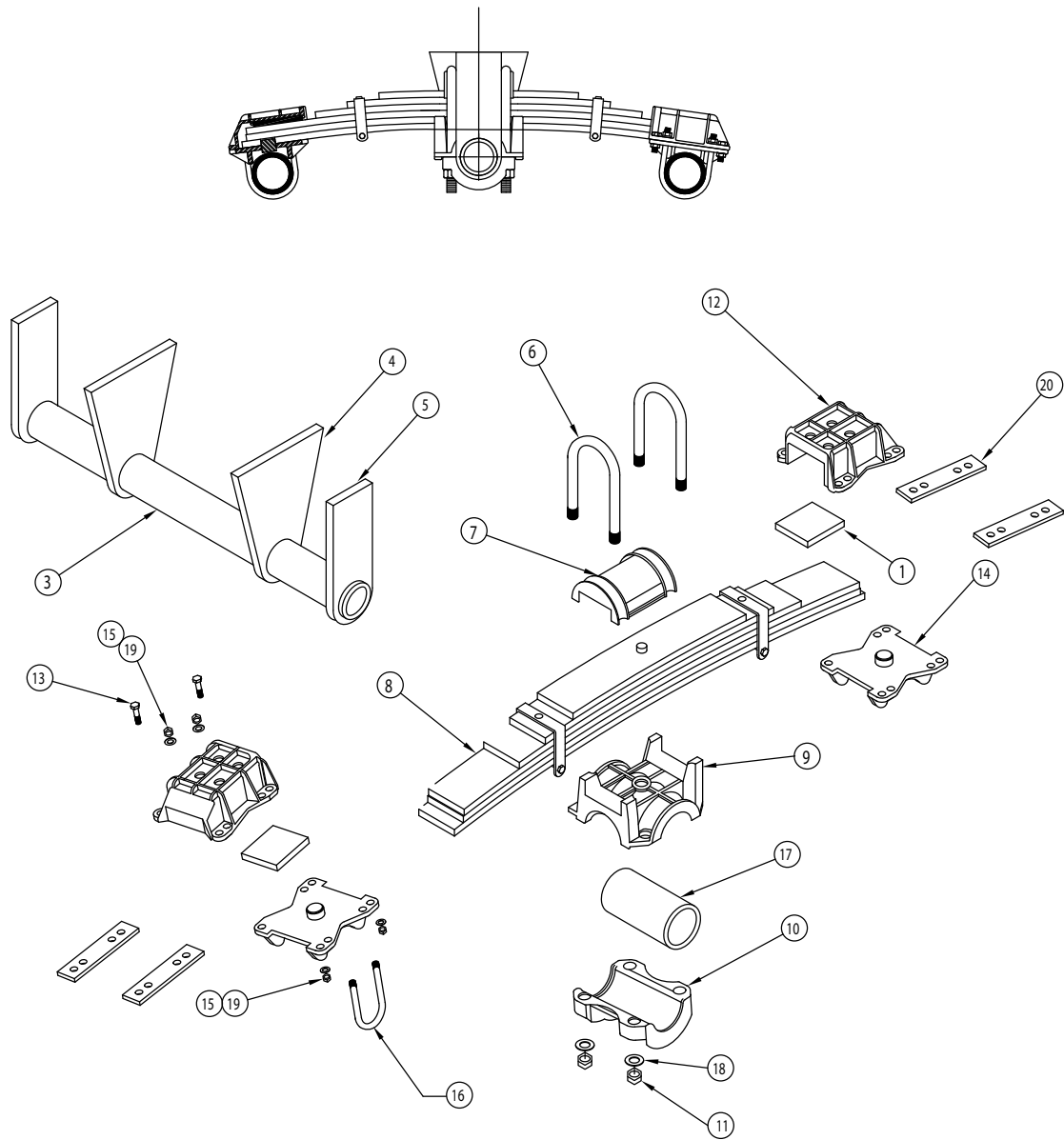

Table 3 SM Single Point Parts List

Item #	Description	Quantity	Part #
1	Polyurethane Pad	4	SP-0193
3	Straddle Trunion Tube Assembly	1	Part number depends on spring centers
4	Inner Straddle Plate	1	Application Specific
5	Outer Straddle Plate	1	Application Specific
6	U-bolt	4	See Chart 3

SP Series

Item #	Description	Quantity	Part #
7	Spring Cap	2	SP-0003
8	Spring	2	See Chart 2
9	Trunnion Cap/Spring Seat	2	SP-0001
10	Trunnion Cap	2	SP-0006
11	High Nut 1.125 UNF. Grade 8	8	10003
12	Cap-Spring End	4	See Chart 2
13	Capscrew .625 X 2.00 UNF. Grade 8	16	10034
14	Axle Seat/Spring Pin Assembly	4	See Chart 2
15	Lock Nut .625 UNF. Grade C	32	10029
16	U-bolt	8	See Chart 2
17	Polyurethane Bushing	2	SP-0192
18	Washer 1.125 Hardened	8	10045
19	Washer .625 Hardened	32	10032
20	Shim Spacer .25" End Cap	8	See Chart 2

Chart 3

Model	Item 6	Item 8	Item 12	Item 14		Item 16		Item 20
				5" Rd. Axle	5" Sq Axle	5" Rd Axle	5" Sq Axle	
HDSM44	SP-0023	SP-0056	SP-0007	SP-0036	SP-0048	SP-0021	SP-0052	N/A
HDSM50	SP-0023	SP-0057	SP-0007	SP-0036	SP-0048	SP-0021	SP-0052	N/A
HDSM60	SP-0022	SP-0243	SP-0007	SP-0036	SP-0048	SP-0021	SP-0052	N/A
LWSM44	SP-0023	SP-0058-01	SP-0016	SP-0036	SP-0048	SP-0021	SP-0052	N/A
LWSM50	SP-0023	SP-0061	SP-0016	SP-0036	SP-0048	SP-0021	SP-0052	SP-0083
LWSMPAR50	SP-0249	SP-0238	SP-0007	SP-0036	SP-0048	SP-0021	SP-0052	SP-0083
HDSM70	SP-0187	SP-0277	SP-0007	SP-0036	SP-0048	SP-0021	SP-0052	N/A
LWSM44-18-5R-60	SP-0023	SP-0212	SP-0007	SP-0036	SP-0048	SP-0021	SP-0052	N/A

SP Series

Figure 4: Exploded View–SMR PAR Single Point

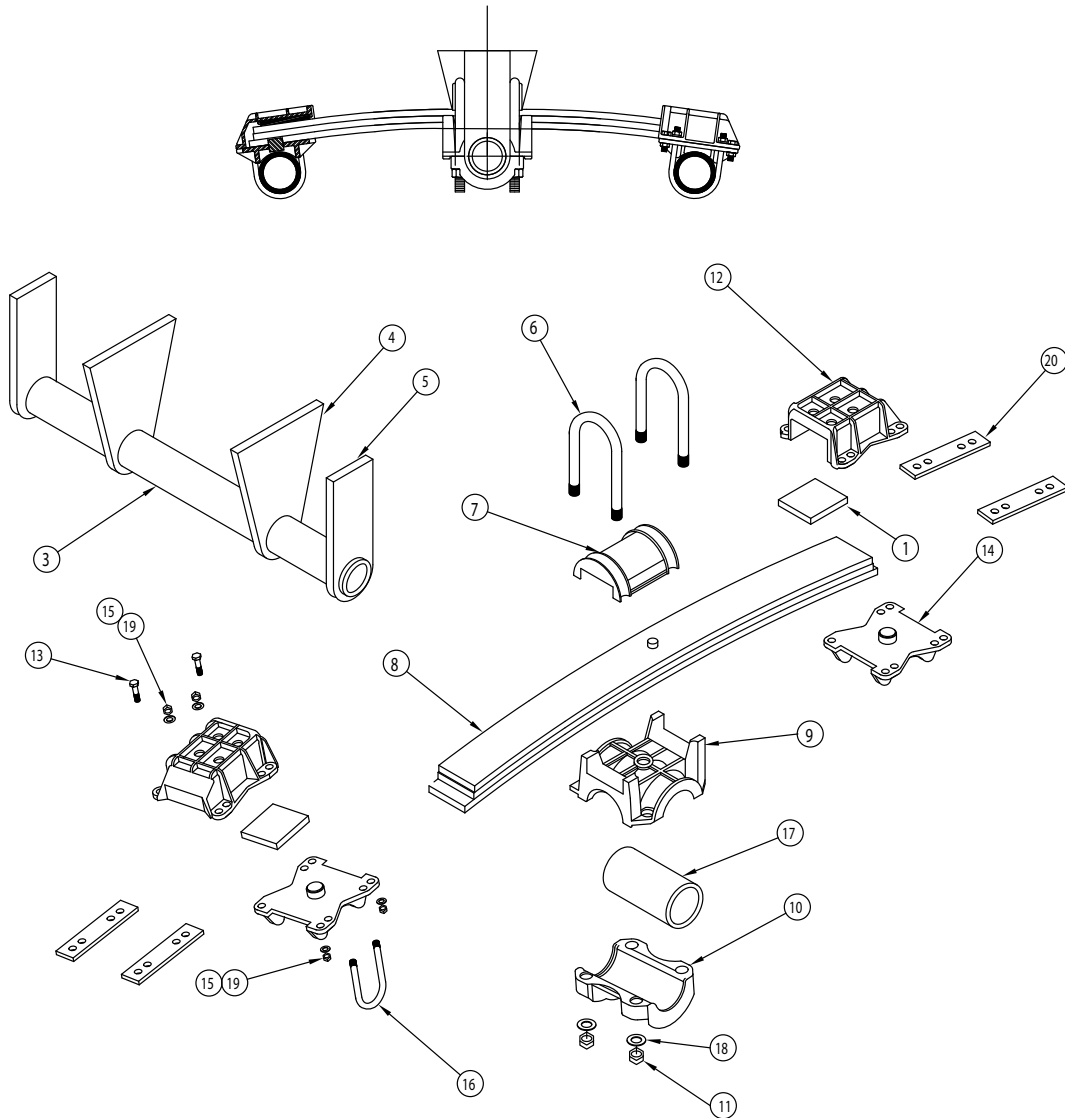

Table 4: SMR PAR Single Point Parts List

Item #	Description	Quantity	Part #
1	Polyurethane Pad	4	SP-0193
3	Straddle Trunnion Tube Assembly	1	Part number depends on spring centers
4	Inner Straddle Plate	1	Application Specific
5	Outer Straddle Plate	1	Application Specific
6	U-bolt 1.125UNFX12.5X5.75 Grade 8	4	SP-0249
7	Trunnion Cap (USR Model)	2	SP-0171
8	Spring	2	SP-0056
9	Trunnion Cap/Spring Seat	2	SP-0001

SP Series

Item #	Description	Quantity	Part #
10	Lower Spring Cap (USR)	2	SP-0177
11	High Nut 1.125 Unf	8	10003
12	Cap-Spring End	4	SP-0007
13	Capscrew .625 X 2.00 UNF. Grade 8	16	10034
14	Axle Seat/Spring Pin Assembly	4	SP-0316
15	Lock Nut .625 UNF Gr C	32	10029
16	U-bolt .62X7.72 Grade 8	8	SP-0021
17	Polyurethane Bushing	2	SP-0225
18	Washer 1.125 Hardened	8	10045
19	Washer .625 Hardened	32	10032
20	Shim Spacer .25" End Cap	8	SP-0083

SP Series

Figure 5: Exploded View-US Single Point

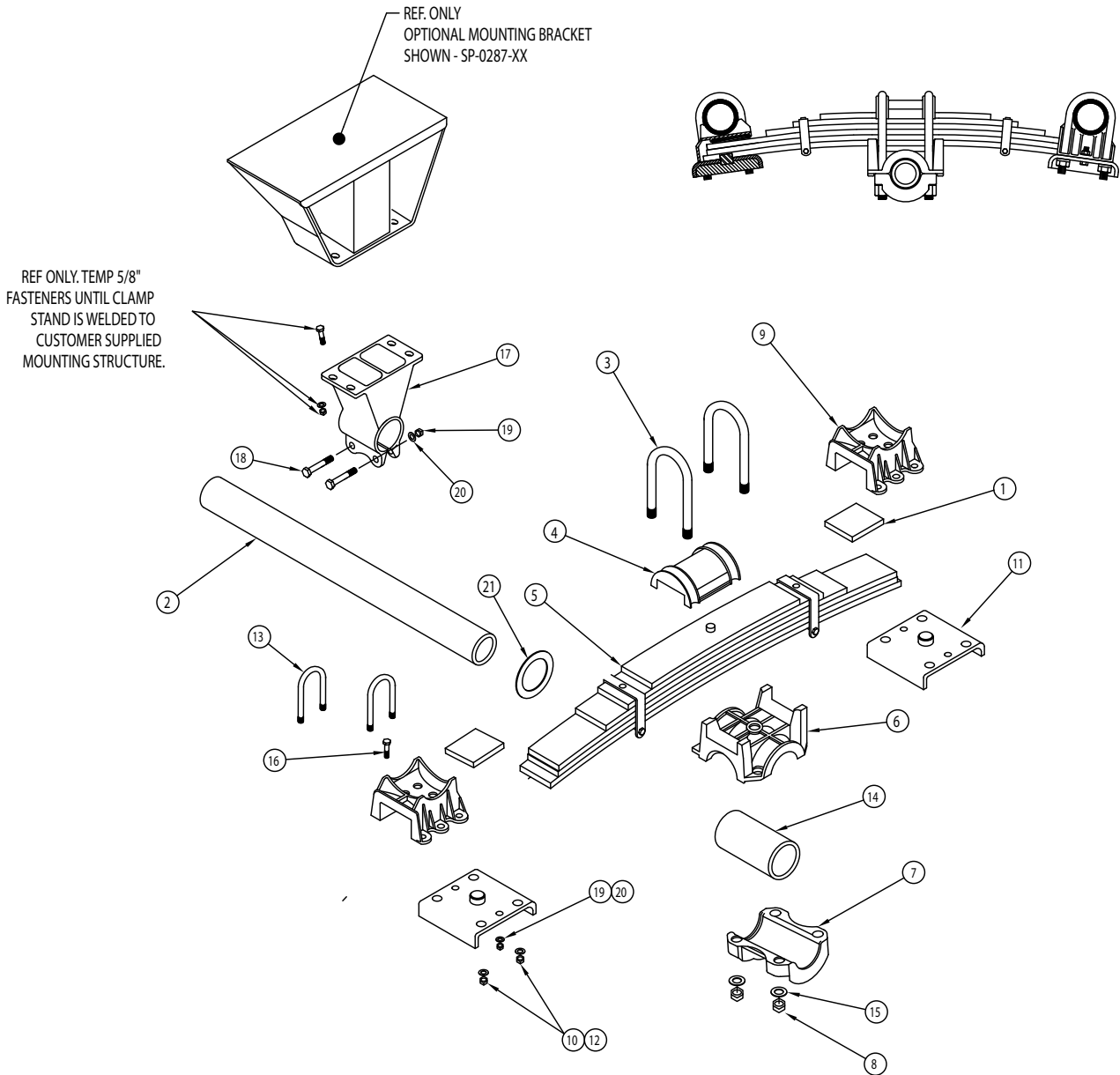

Table 5 US Single Point Parts List

Item #	Description	Quantity	Part #
1	Polyurethane Pad	4	SP-0193
2	Trunnion Tube	1	Part number depends on spring centers
3	U-bolt	4	See Chart 5
4	Spring Cap	2	SP-0003
5	Spring	2	See Chart 5
6	Trunnion Cap/Spring Seat	2	SP-0001
7	Trunnion Cap	2	SP-0006
8	High Nut 1.125 UNF Grade 8	8	10003

SP Series

Item #	Description	Quantity	Part #
9	Axle Seat/Spring End Cap	4	See Chart 5
10	High Nut 1.00 UNF.	16	See Chart 5
11	Bottom Plate / Pin Assembly	4	See Chart 5
12	Washer 1.00	16	See Chart 5
13	U-bolt	8	See Chart 5
14	Polyurethane Bushing	2	SP-0192
15	Washer 1.125 Hardened	8	10045
16	Capscrew .75 UNF 2.50 Long Grade 8	8	10896-01
17	Trunnion Clamp Stand	2	See Chart 5A
18	Capscrew .75 X 5.0 UNF Gr. 8	4	10033
19	Lock Nut .75 UNF Grade C	12	10028
20	Washer .75 Hardened	12	10043
21	Washer Flat 4.12X6.00X.12	2	17023

Chart 5

Model	Item 3	Item 5	Item 9			Item 10		Item 11		Item 12		Item 13		
			5" Rd. Axle	5" Sq. Axle	5.75" Rd. Axle	5" Rd. Axle	5.75" Rd. Axle	5" Rd. Axle	5.75" Rd. Axle	5" Rd. Axle	5.75" Rd. Axle	5" Rd. Axle	5" Sq. Axle	5.75" Rd. Axle
HDUS44	SP-0023	SP-0056	SP-0013	SP-0345	SP-0327	10031	10003	SP-0029	SP-0316	17099	10045	SP-0020	SP-0348	SP-0227
HDUS50	SP-0023	SP-0057	SP-0013	SP-0345	SP-0327	10031	10003	SP-0029	SP-0316	17099	10045	SP-0020	SP-0348	SP-0227
HDUS60	SP-0022	SP-0243	SP-0013	SP-0345	SP-0327	10031	10003	SP-0029	SP-0316	17099	10045	SP-0020	SP-0348	SP-0227
HDUS70	SP-0022	SP-0277	SP-0013	SP-0345	SP-0327	10031	10003	SP-0029	SP-0316	17099	10045	SP-0020	SP-0348	SP-0227
LWUS44	SP-0022	SP-0058-01	SP-0086-01	N/A	N/A	10031	N/A	SP-0029	N/A	17099	N/A	SP-0020	N/A	N/A
LWUS50	SP-0023	SP-0061	SP-0084	N/A	N/A	10031	N/A	SP-0029	N/A	17099	N/A	SP-0020	N/A	N/A

Chart 5A

Item 17	
Clamp Stand Height	Part No.
8.5"	SP-0009
6.5"	SP-0010
4.5"	SP-0011
2.5"	SP-0012

SP Series

Figure 6: Exploded View-SMUS Single Point

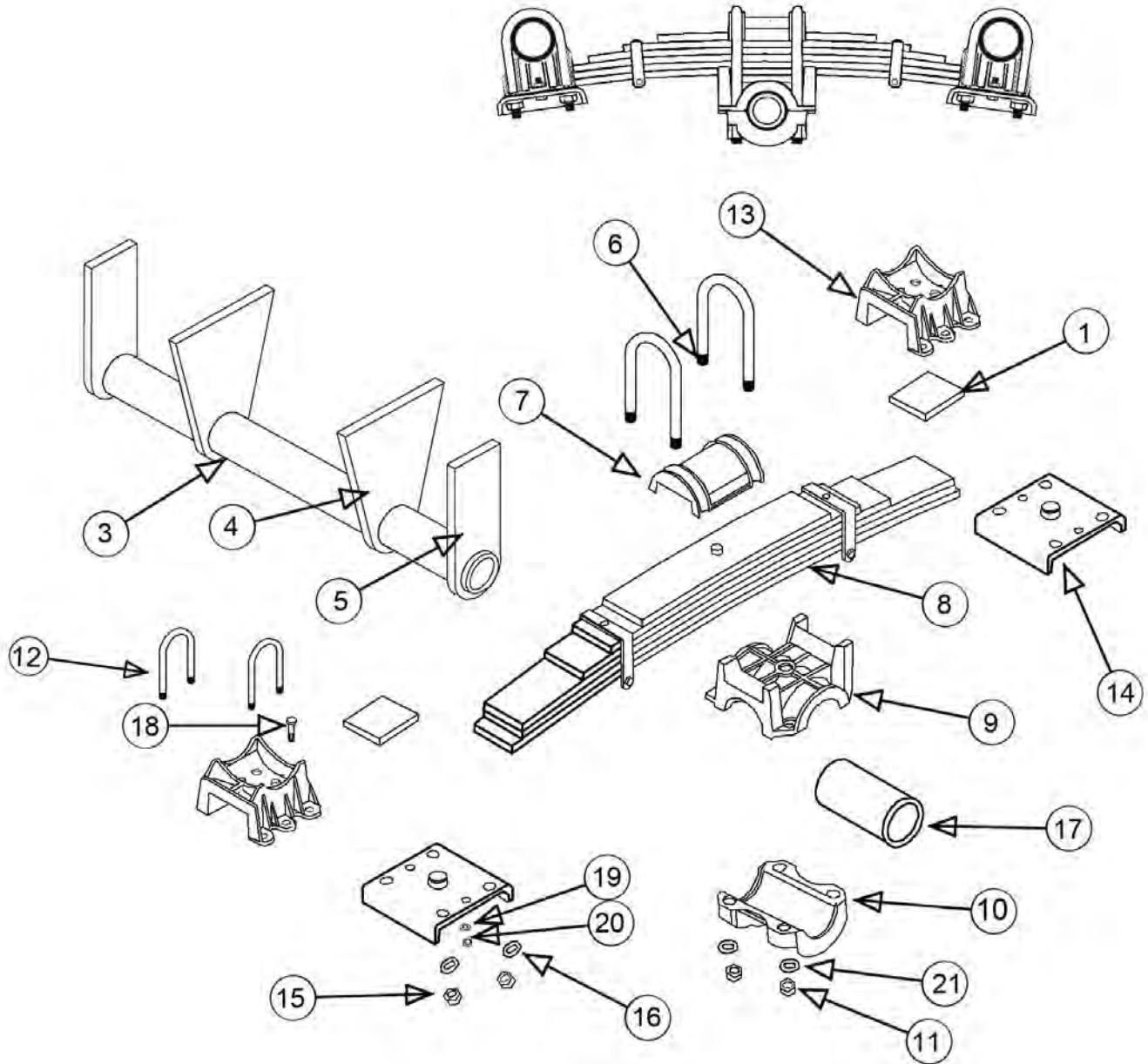

Table 6 SMUS Single Point Parts List

Item #	Description	Quantity	Part #
1	Polyurethane Pad	4	SP-0193
3	Trunnion Tube	1	Part number depends on spring centers
4	Inner Straddle Plate	1	Application Specific
5	Outer Straddle Plate	1	Application Specific
6	U-bolt	4	See Chart 6
7	Spring Center Cap	2	SP-0003
8	Spring	2	See Chart 6

SP Series

Item #	Description	Quantity	Part #
9	Trunnion Cap/Spring Seat	2	SP-0001
10	Trunnion Cap	2	SP-0006
11	High Nut 1.125 UNF Grade 8	8	10003
12	U-bolt 1.00-14X11 Grade 8	8	SP-0020
13	Axle Seat/Spring End Cap	4	See Chart 6
14	Bottom Plate Pin Assembly	4	SP-0029
15	High Nut 1.00 UNF.	16	10031
16	Washer 1.00	16	17099
17	Polyurethane Bushing	2	SP-0225
18	Capscrew .75 UNF 2.50" Long	8	10896-01
19	Flat Washer .75 Hardened	8	10043
20	Locknut .75 UNF GR C	8	10028
21	Washer. 1.125 Hardened	8	10045

Chart 6

Model	Item 6	Item 8	Item 13	
			5" Rd Axle	5" Sq Axle
HDSUSM44	SP-0023	SP-0056	SP-0013	N/A
HDSMUS50	SP-0023	SP-0057	SP-0013	N/A
HDSMUS60	SP-0022	SP-0060	SP-0013	N/A
LWSMUS44	SP-0023	SP-0058-01	SP-0086-01	N/A
LWSMUS50	SP-0023	SP-0061	SP-0084	N/A
HDSMUS70	SP-0187	SP-0170	SP-0013	N/A

SP Series

Figure 7: Exploded View-PPSM Single Point with Heavy Duty End caps

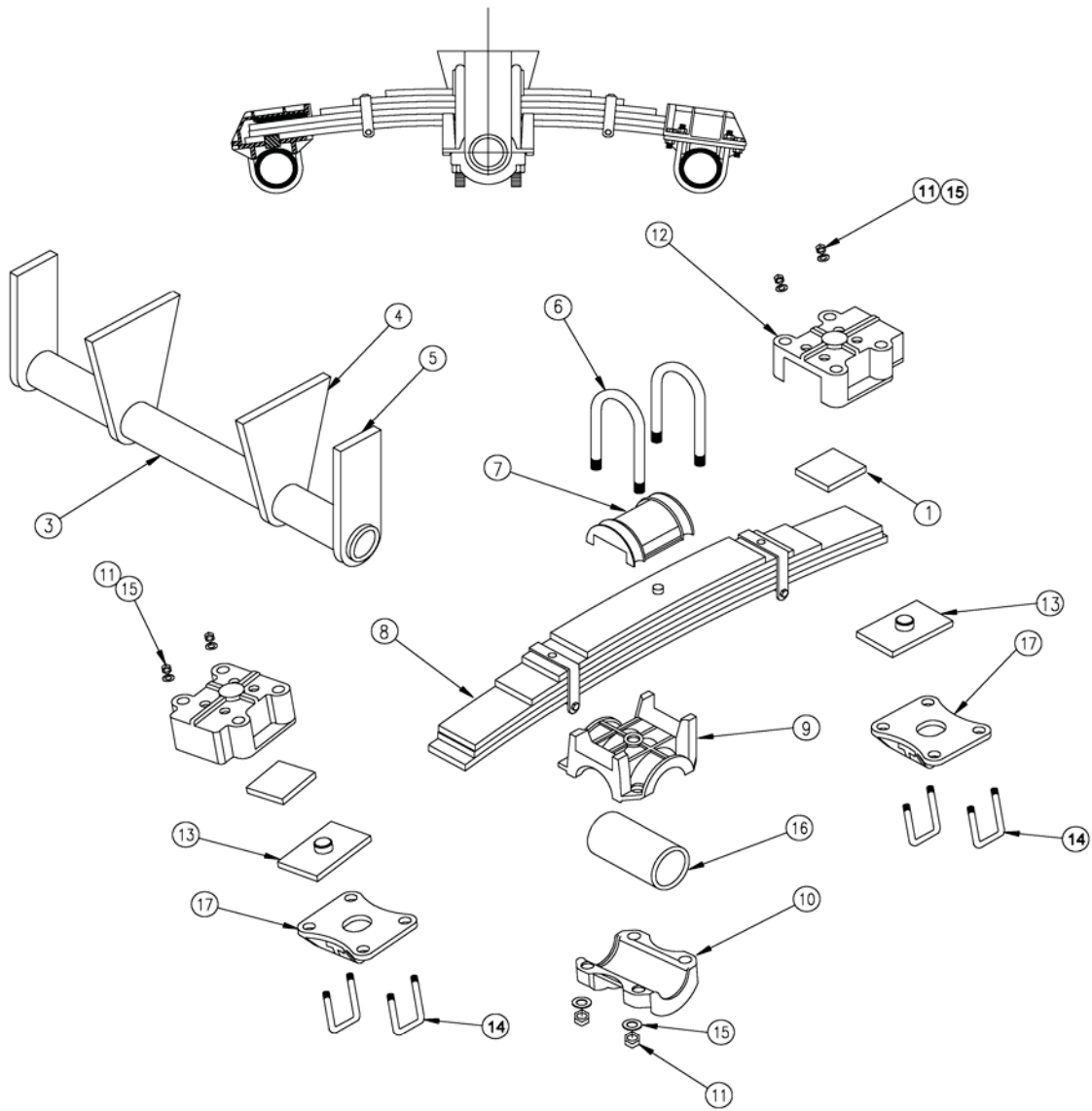

Table 7 PPSM Single Point with Heavy Duty End Caps Parts List

Item #	Description	Quantity	Part #
1	Polyurethane Pad	4	SP-0039
3	Trunnion Tube	1	Part number depends on spring centers
4	Inner Straddle Plate	1	Application Specific
5	Outer Straddle Plate	1	Application Specific
6	U-bolt	4	See Chart 7
7	Spring Center Cap	2	SP-0003
8	Spring	2	See Chart 7
9	Trunnion Cap/Spring Seat	2	SP-0001
10	Trunnion Cap	2	SP-0006

SP Series

Item #	Description	Quantity	Part #
11	High Nut 1.125 UNF Grade 8	8	10003
12	Cap Spring End	4	SP-0015
13	Slide Plate Pin Assembly	4	Sp-0195
14	U-bolt 1.12-12 Grade 8	8	SP-0094
15	Washer 1.125 Hardended	8	10045
16	Polyurethane Bushing	2	SP-0225
17	Axle Seat Propar 5" Dia.	4	SP-0092

Chart 7

Model	Item 6	Item 8
PPSM-50	SP-0023	SP-0058
PPSM-60	SP-0022	SP-0060
PPSM-70	SP-0187	SP-0170

SP Series

Figure 8: Exploded View-TSR Single Point

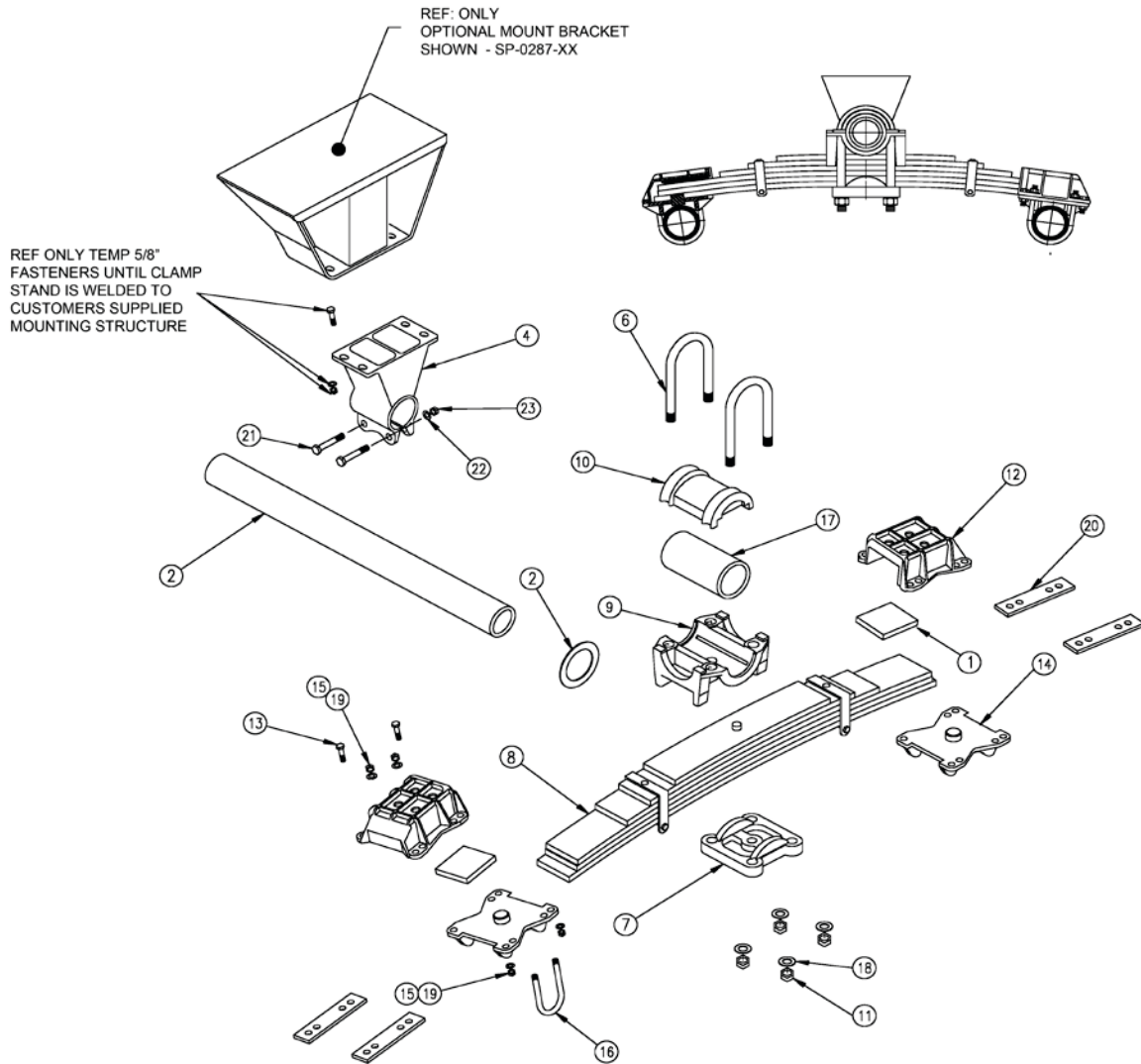

Table 8 TSR Single Point Parts List

Item #	Description	Quantity	Part #
1	Polyurethane Pad	4	SP-0193
2	Washer Flat 4.12X6.00X.12	4	SP-0038
3	Trunnion Tube	1	Part number depends on spring centers
4	Trunnion Clamp Stand	2	See Chart 8A
6	U-bolt	4	See Chart 8
7	Spring Cap	2	SP-0177
8	Spring	2	See Chart 8
9	Trunnion Cap/Spring Seat	2	SP-0001
10	Trunnion Cap	2	SP-0171

SP Series

Item #	Description	Quantity	Part #
11	High Nut 1.00 Unf.	8	10003
12	Cap Spring End	4	See Chart 8
13	Capscrew .625 UNF	16	See Chart 8
14	Axle Seat Spring Pin Assembly	4	See Chart 8
15	Lock Nut .625 UNF Grade 8	32	10029
16	U-bolt	8	See Chart 8
17	Polyurethane Bushing	2	SP-0193
18	Washer 1.125 Hardened	8	10045
19	Washer .625 Hardened	32	10032
20	Shim Spacer .25" End Cap	8	See Chart 8
21	Capscrew .75 X 5.0 UNF Gr. 8	4	10033
22	Washer .75	12	10043
23	Lock Nut .75 UNF Grade 8	12	10028

Chart 8

Model	Item 6	Item 8	Item 12	Item 13	Item 14		Item 16		Item 20
					5." Rd. Axle	5" Sq. Axle	5." Rd. Axle	5" Sq. Axle	5" Rd. Axle
HDTSR44	SP-0023	SP-0056	SP-0007	10034	SP-0036	SP-0048	SP-0021	SP-0052	N/A
HDTSR50	SP-0022	SP-0057	SP-0007	10034	SP-0036	SP-0048	SP-0021	SP-0052	N/A
HDTSR60	SP-0022	SP-0060	SP-0007	10034	SP-0036	SP-0048	SP-0021	SP-0052	N/A
LWTSR44	SP-0023	SP-0058-01	SP-0016	10034	SP-0036	SP-0048	SP-0021	SP-0052	N/A
LWTSR50	SP-0023	SP-0061	SP-0016	10396	SP-0036	SP-0048	SP-0021	SP-0052	SP-0083
LWTSRPAR50	SP-0249	SP-0056	SP-0007	10034	SP-0036	SP-0048	SP-0021	SP-0052	SP-0083

Chart 8A

Item 17	
Clamp Stand Height	Part No.
8.5"	SP-0009
6.5"	SP-0010
4.5"	SP-0011
2.5"	SP-0012

SP Series

Figure 9: Exploded View-USR Single Point

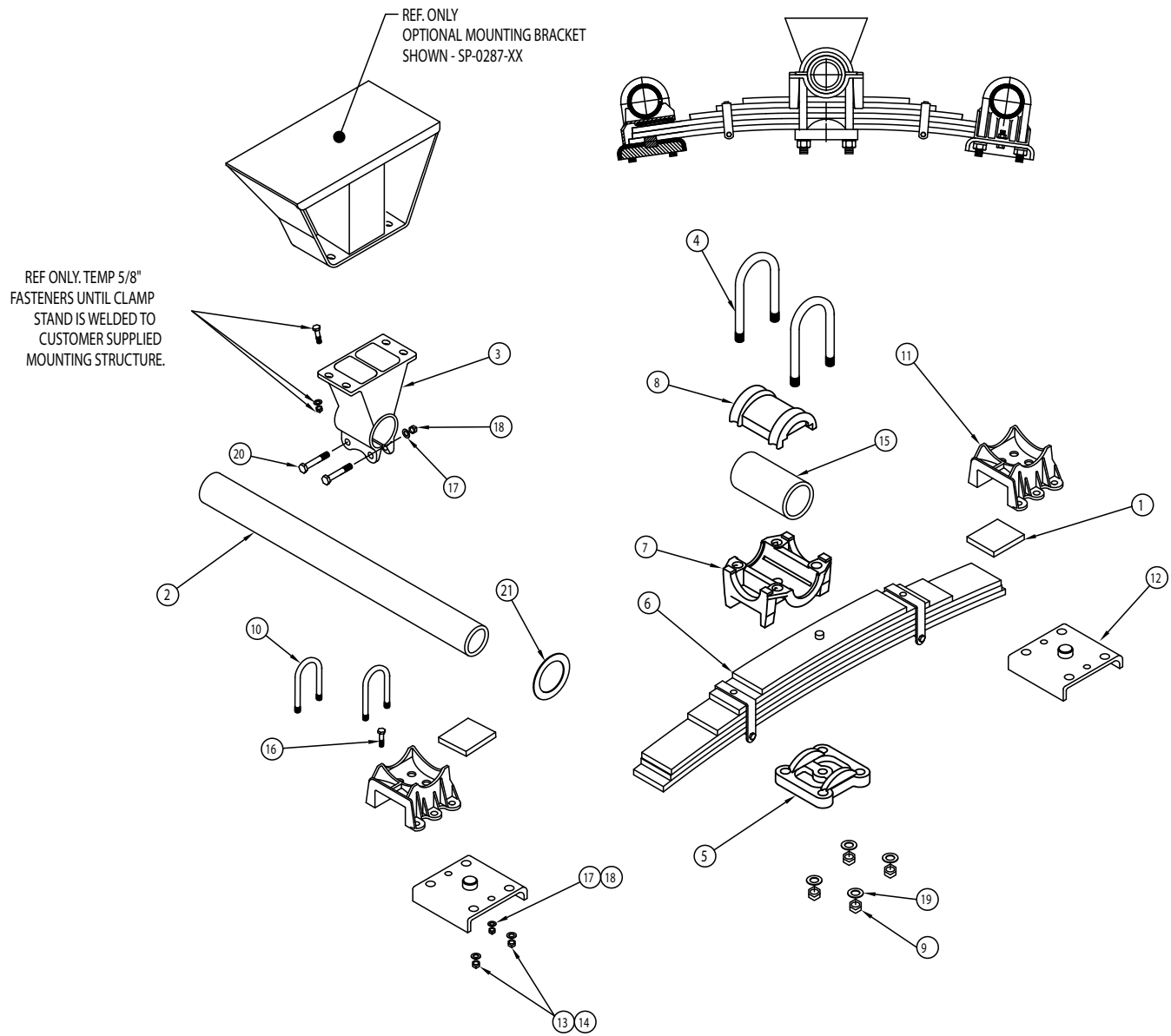

Table 9 TSR Single Point Parts List

Item #	Description	Quantity	Part #
1	Polyurethane Pad	4	SP-0193
2	Trunnion Tube	1	Part number depends on spring centers
3	Trunnion Clamp Stand	2	See Chart 9A
4	U-bolt	2	See Chart 9
5	Lower Spring Cap	2	SP-0177
6	Spring	2	See Chart 9
7	Trunnion Cap/Spring Seat	2	SP-0001
8	Trunnion Cap	2	SP-0171
9	High Nut	8	1003
10	U-bolt	8	SP0020

SP Series

Item #	Description	Quantity	Part #
11	Axle Seat Spring Pin Assembly	4	See Chart 9
12	Bottom Plate / Pin Assembly	4	SP-0029
13	High Nut 1.00 UNF	16	10031
14	Washer Flat 1.06 x 1.75 Hardened	16	17099-01
15	Polyurethane Bushing	2	SP-0192
16	Capscrew .75 UNF 2.50 Long Hardened	8	10896-01
17	Washer .75 Hardened	12	10043
18	Lock Nut .75 UNF Grade 8	12	10028
19	Washer 1.125 Hardened	8	10045
20	Capscrew .75 UNF 5.0 Grade 8	4	10033
21	Washer Flat 4.12 x 6.00 x .12	2	SP-0038

Chart 9

Model	Item 4	Item 6	Item 11	
			5." Rd. Axle	5" Sq. Axle
HDUSR44	SP-0023	SP-0056	SP-0013	N/A
HDUSR50	SP-0023	SP-0057	SP-0013	N/A
HDUSR60	SP-0022	SP-0243	SP-0013	N/A
HDUSR70	SP-0187	SP-0277	SP-0013	N/A
LWUSR44	SP-0023	SP-0058-01	SP-0058-01	N/A
LWUSR50	SP-0023	SP-0061	SP-0061	N/A

Chart 9A

Item 17	
Clamp Stand Height	Part No.
8.5"	SP-0009
6.5"	SP-0010
4.5"	SP-0011
2.5"	SP-0012

Figure 10: Exploded View-SLIDE PAD OPTION

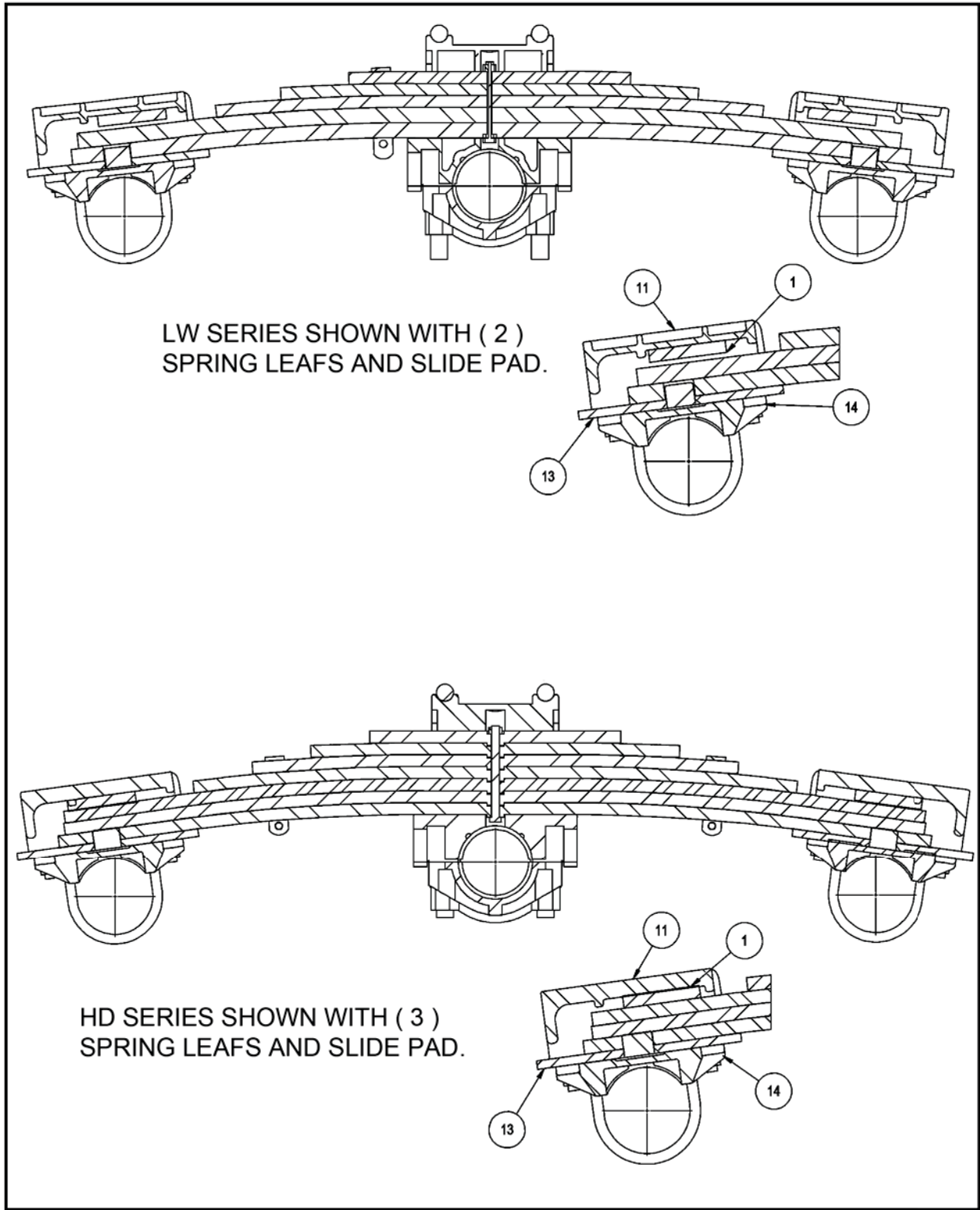

SP Series

Figure 10: Exploded View-SLIDE PAD OPTION

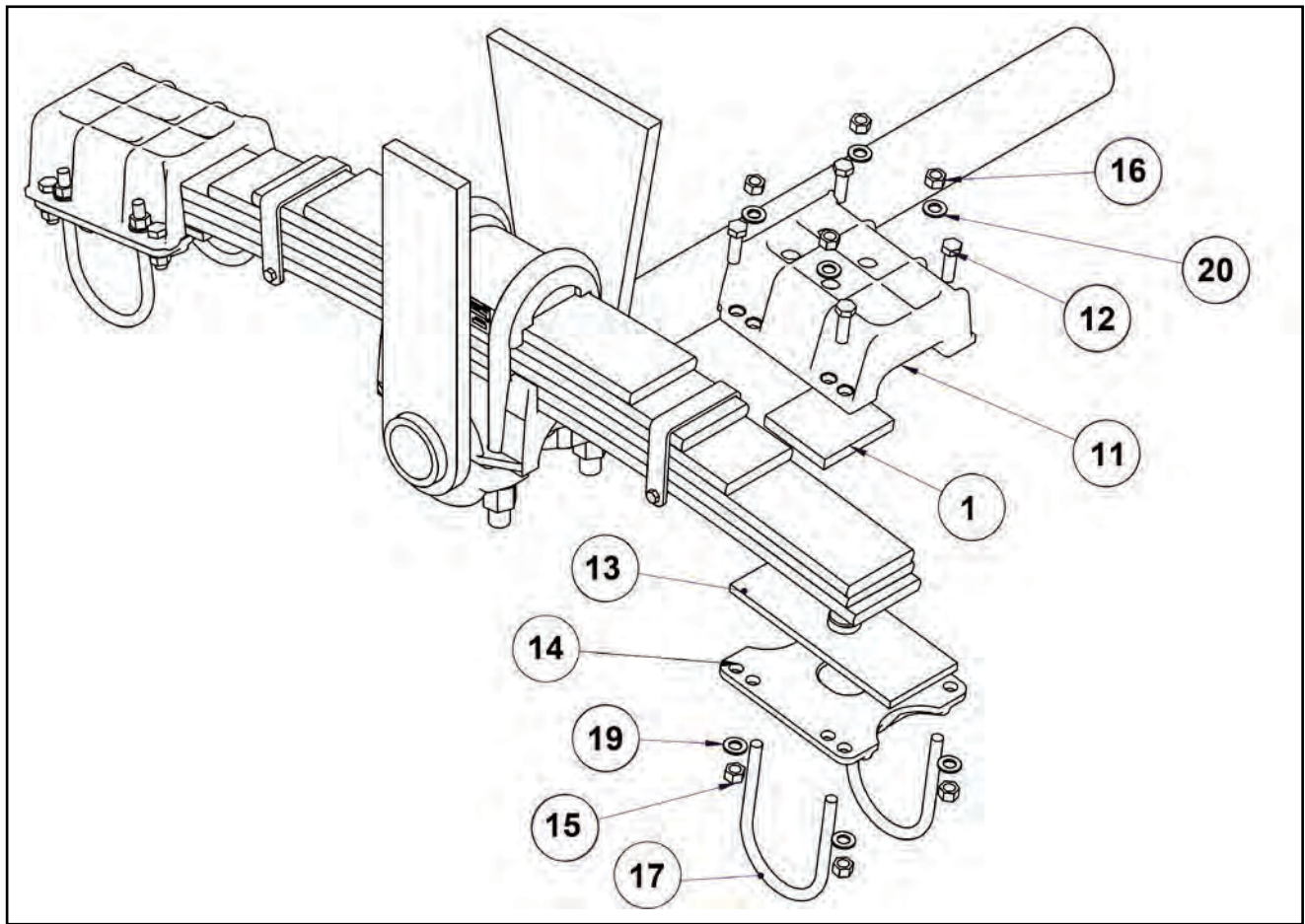

SLIDE PAD OPTION PARTS

Ref Watson & Chalin Mfg Drawing "SMXX"

	ITEM #1	ITEM #11	ITEM #12	ITEM #13	ITEM #14
MODEL NO.	Poly Pad	AXLE SEAT CASTING TOP	CAPSCREW .62X2.00 UNF GR8	SLIDE PAD PIN ASSEMBLY	5" DIAMETER AXLE SEAT CASTING LOWER
HDSM44	SP0193	19091-03	10034	SP0377	19092
HDSM50		19091-03			
HDSM60		19091-03			
LWSM44		19091-02			
LWSM50		19091-02			
LWSMPAR50		19091-03			
HDSM70		19091-03			
	ITEM #15	ITEM #16	ITEM #17	ITEM #19	ITEM #20
MODEL NO.	NUT LOCK .62 UNF GR-C	1.12 HIGH NUT	5" DIAMETER AXLE U-BOLT 1.12 X 7.50	FLAT WASHER	WASHER FLAT HARDENED
HDSM44	10029	10003	SP0021	10032	10045
HDSM50					
HDSM60					
LWSM44					
LWSM50					
LWSMPAR50					
HDSM70					

SP Series

Installation

Seat Type Identification

Important

The following instructions are for installing the components of the Watson & Chalin SP Series Suspension systems. All model numbers in the series are installed using this same set of instructions. Watson & Chalin assumes that the correct suspension and axle were chosen based on the individual design criteria.

Please read all instructions before installation as some procedures differ for the "Slide Pad" version from those used for the WC standard version.

Items that are "Slide Pad" specific will be highlighted by the diamond border like the one on this page.

The following illustration shows the difference between the "Slide Pad" (Figure 10 A) and the "Watson & Chalin Standard" version (Figure 10 B).

Please contact Watson & Chalin should you have any questions about which is your version before you precede with installation.

SLIDE PAD ONLY SPECIAL INSTRUCTIONS

- **Slide Pad** version axle seat does not have a spring pin in it and will come with the separate Slide Pad. The Slide Pad does have the pin.
- **Precede to Page 25 for Slide Pad Installation instructions.**

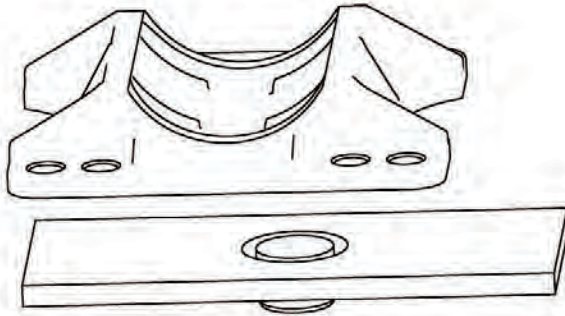

Figure 10 A:

- **Watson & Chalin Standard** version axle seat does have a spring pin in it and will not come with the separate Slide Pad.
- If you are using **Watson & Chalin Standard** Follow instructions on pages 22 thru 24 then skip to page 27 .



Figure 10 B:

SP Series

Prior to Installing the WC Standard SP-Series Suspension

These pages for Installing the Standard SP-Series Suspension Only
Go to page 25 if using the “Slide Pad” version

Please inspect the SP assembly prior to any installation and be sure the alignment has not moved during shipping. **See Figure 11**

Check parallel relationship of springs to each other and also perpendicularity of springs to the trunnion tube. Adjust as necessary. Ensure nuts on the trunnion cap U-bolts are tightened to the specified torque requirements. **See torque table.**

Figure 11:

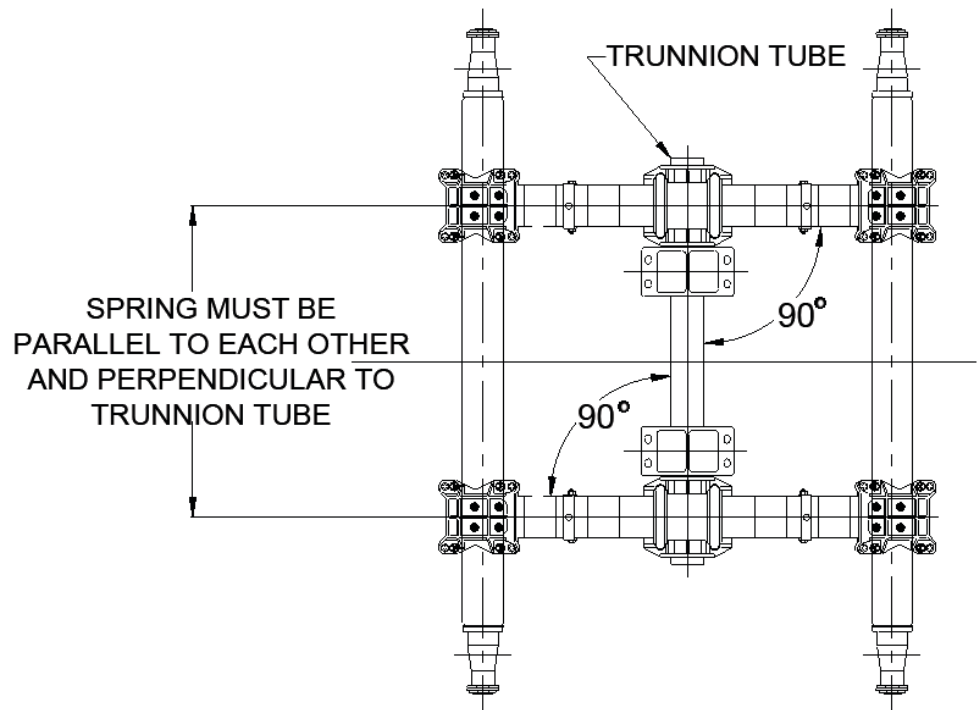

SP Series

Installing the Axles

1. Install axles and temporarily secure in place with u-bolts, washers and nuts. Leave u-bolts loose enough for axle adjusting.
2. With the axles in place, check the following:
 - Axle camber, if applicable, is located on top and perpendicular to flat of Spring End Pad
 - Casting or 1/4" to the outside of vertical centerline of axle.
 - Axles are centered laterally on suspension. Measure from brake flange to centerline of spring, ensuring equal distance both sides. **See figure 12**
 - Axle brake cam rotation is in the same direction as the forward rotation of the wheels.
 - It is important that the axle spacing is exactly the same at both ends of each axle.
3. Tighten U-bolts securely but do not put final torque on at this time, then recheck Step 2.
4. Check tire clearance with suspension.

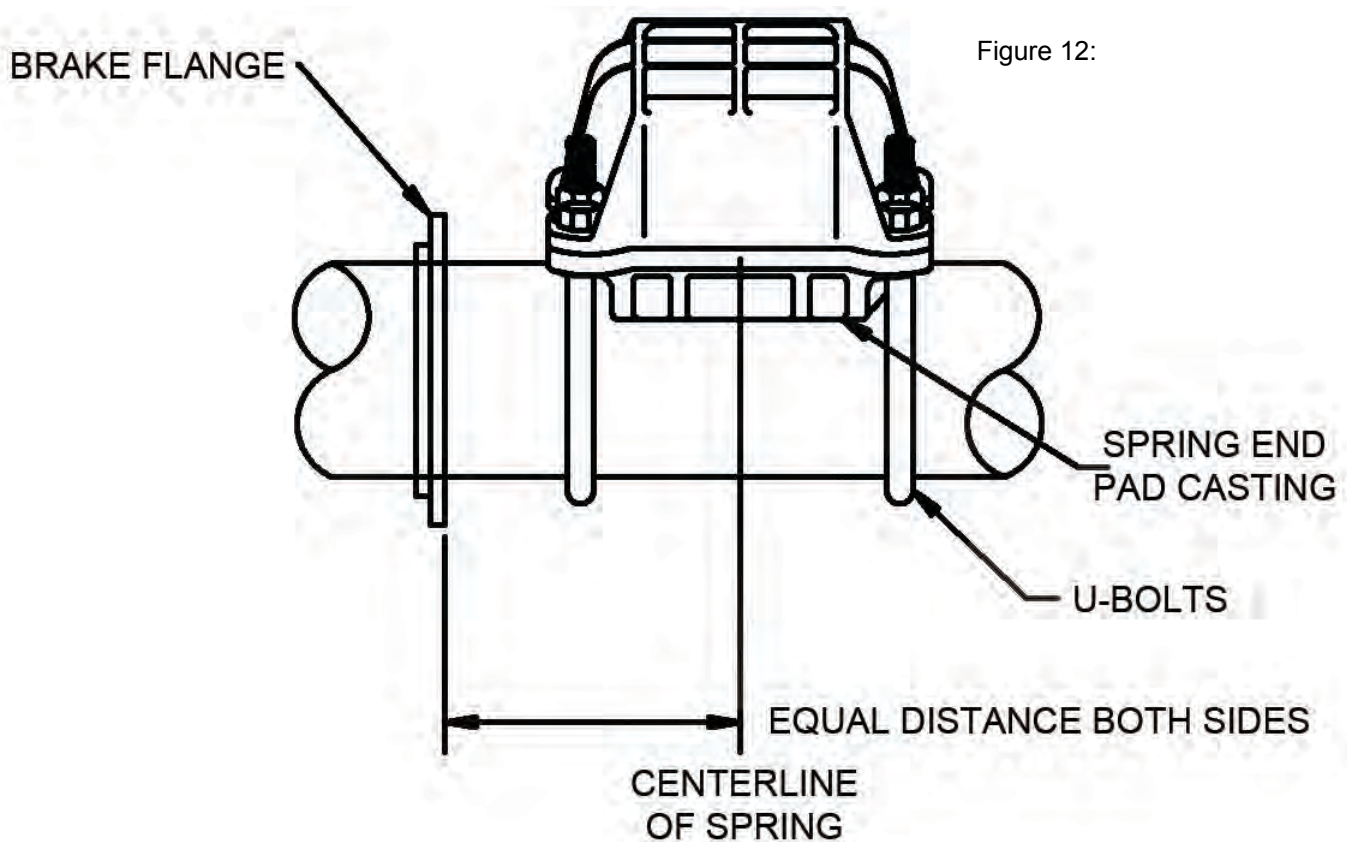

Note

The "Standard" spring end pad casting is designed so axles may be shifted 3/16" in either direction. Place wedges between axle and spring end pad casting to hold axle in position.

The following 2 pages are for the Slide Pad version only. Please turn to page 27 if you are using the Watson & Chalin Standard version SP Suspension

SP Series

SLIDE PAD ONLY

Prior to Installing *Slide Pad Version* of the SP-Series Suspension

Please inspect the SP assembly prior to any installation and be sure the alignment has not moved during shipping. **See Figure 13.**

Check parallel relationship of springs to each other and also perpendicularity of springs to the trunnion tube. Adjust as necessary.

Ensure nuts on the trunnion cap U-bolts are tightened to the specified torque requirements. **See torque table.**

Check to be sure:

- Axle camber, if applicable, is located on top and perpendicular to flat of Spring End Pad Casting or 1/4" to the outside of vertical centerline of axle.
- Axles are centered laterally on suspension. Measure from brake flange to centerline of spring, ensuring equal distance both sides. **See figure 14**
- Axle brake cam rotation is in the same direction as the forward rotation of the wheels.
- Axle spacing is exactly the same at both ends of axles.

Installing the Axles

1. Tack weld Axle seats in place and then re-check above listed alignments.

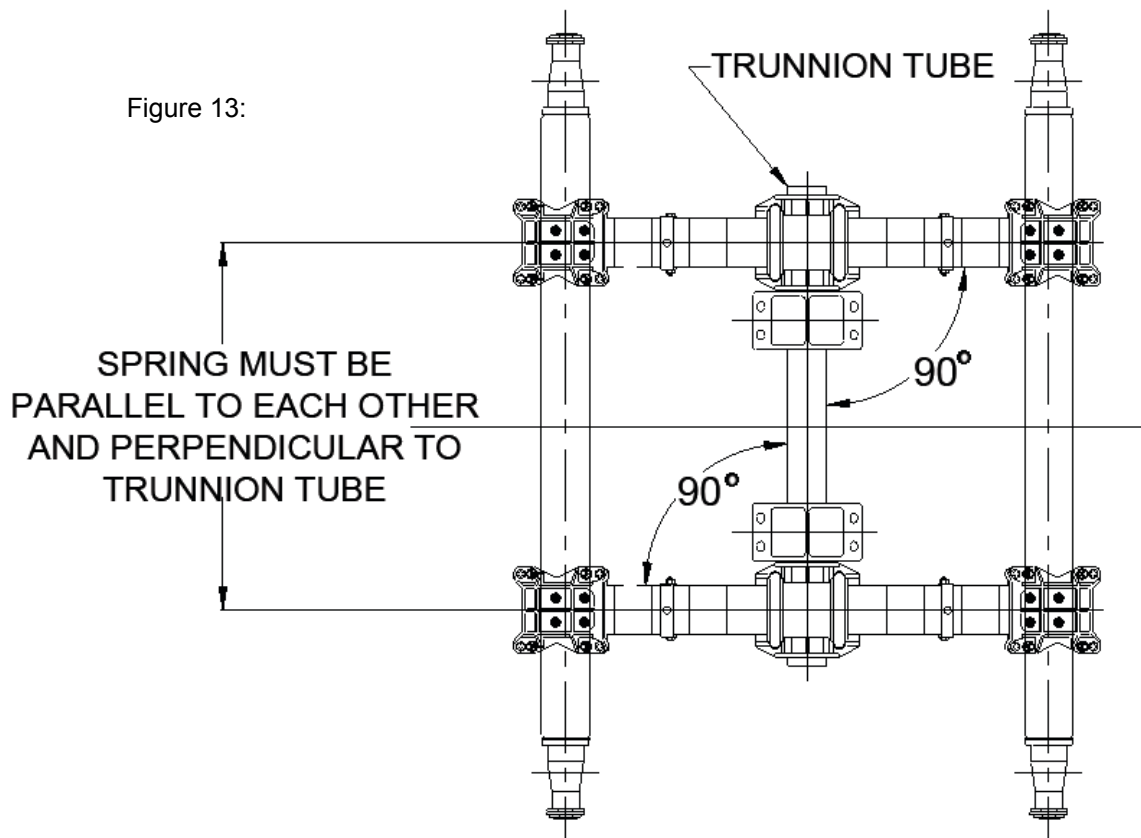

SLIDE PAD ONLY

Installing the Axles - Continued.

2. Weld axles securely to Spring End Pad Castings, following the axle manufacturer's welding recommendations, using 3/8" fillet welds on the front and rear of the axle seats. Use welding rod AWS-Spec. E-70xx or equivalent. **See figure 14**

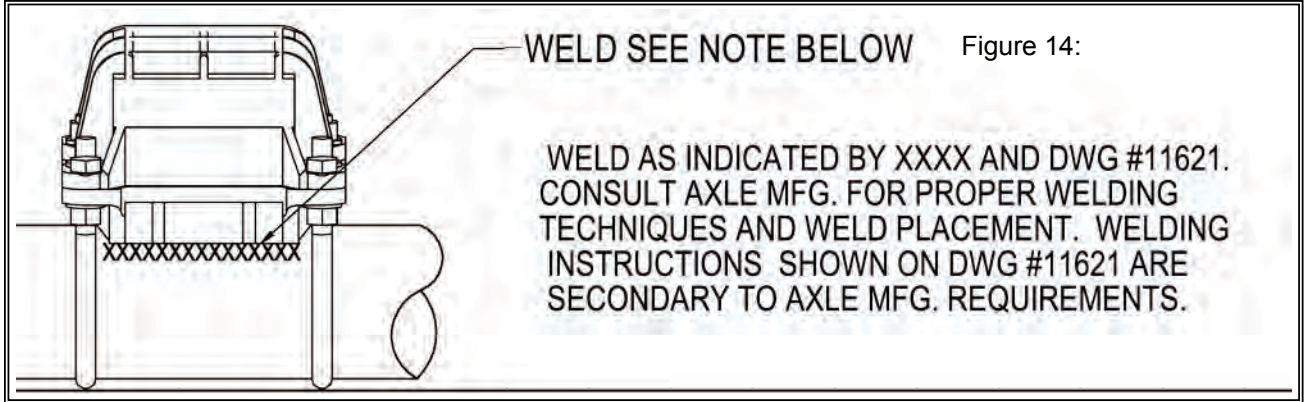
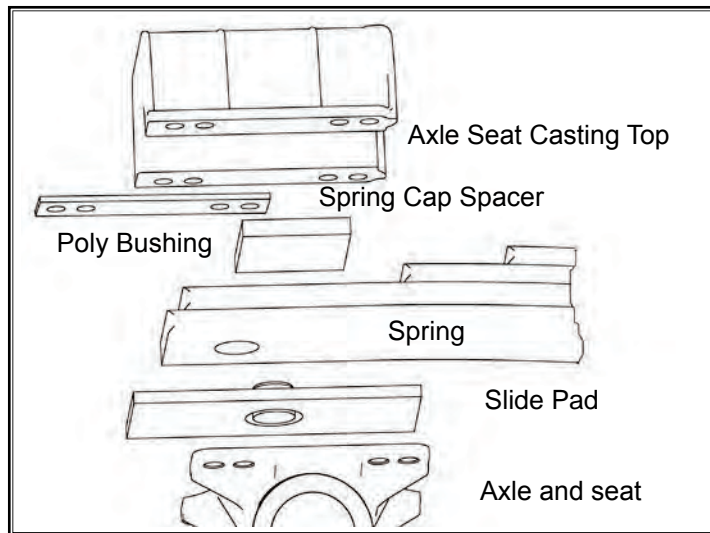

Figure 15:



3. Assemble Spring ends with U-Bolts, Axle/Seat Assembly, Slide Pad, Poly Bushing, Spring Cap Spacer (if required), Axle Seat Casting Top, and 5/8" cap screws. Do not tighten these nuts/bolts at this time. **See Figure 15**

Follow directions on page 27 and proceeding for Both Slide Pad and WC Standard.

SP Series

Preparing the Trailer Frame

Follow these directions and proceeding pages for Both Slide Pad and WC Standard versions.

1. To determine the centerline of tandem, measure from king-pin and scribe a vertical line on outside of both frame members. **See figure 16**

See figure 16

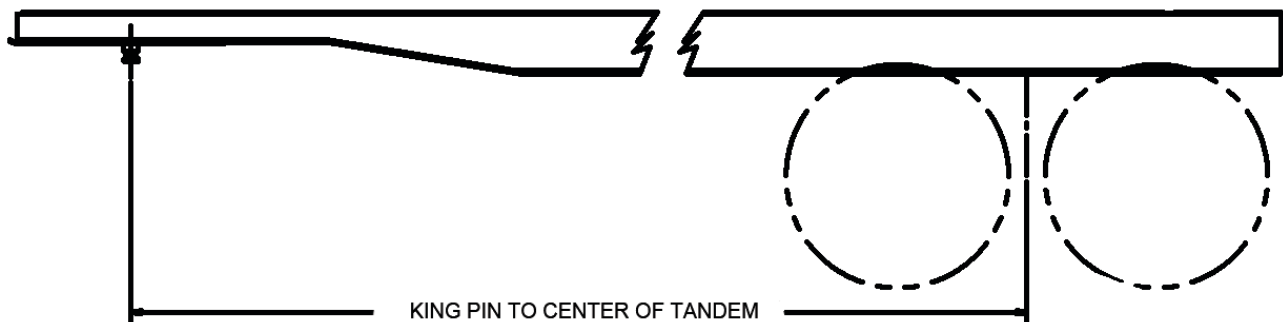

2. Prepare the frame for installation of the suspension in one of the following ways:

- Use of optional Watson & Chalin mounting brackets - SP-0287-XX (2 required per tandem suspension). See exploded views for pedestal type suspension.
- Customer furnished fabricated mounting brackets.
- Fastening directly to frame.

3. Install crossmembers and gussets as shown in **See figure 17**. Use welding rod AWS-Spec. E-70xx or equivalent

Note

The trailer structure shown in figure 17 is intended to be a generic representation of a typical installation, and is not intended to be a detailed recommendation for a fabrication of trailer subframe. The welds attaching the mounting bracket to the subframe will be determined by the configuration of the structure, and are the responsibility of the installer.

Additional customer furnished bracing is required to connect mounting brackets to each other.

See figure 17

SP Series

• Figure 17:

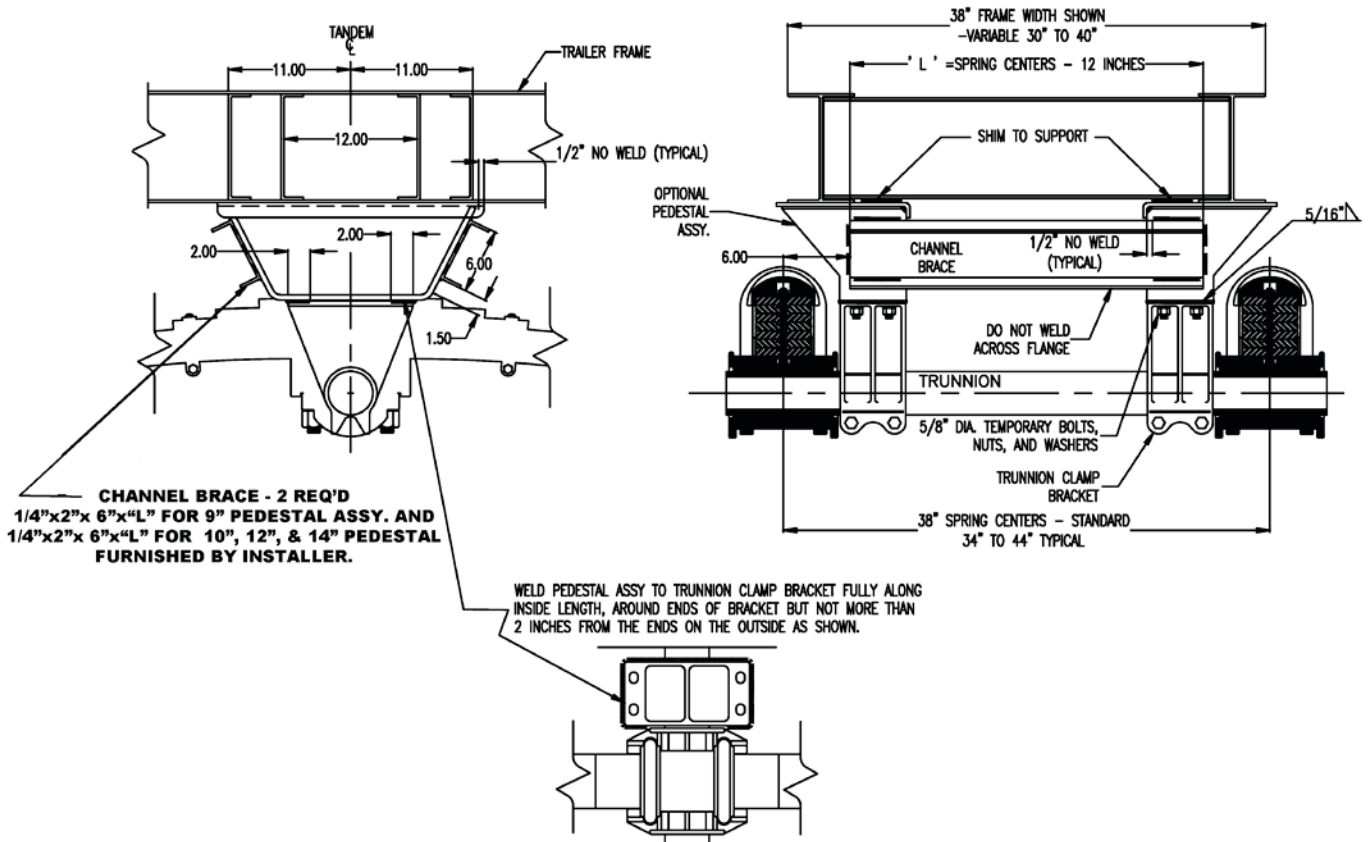

Assembling Tandem To Trailer Trunnion Mount

1. Install inside tires on suspension and roll unit under frame to proper centerline location. Installation of tires is not necessary at this time if a suitable dolly is used, or on trailer production lines where trailers are sometimes bottom side up.
2. Center suspension on trailer frame tandem Frame Bracket.
3. Assemble to Trunnion Clamp Castings, with 5/8" bolts, nuts and washers, leaving loose enough for adjustment.
4. Check alignment of trunnion tube axle to king-pin and shift entire suspension, if necessary, until distances A and B are equal. **See figure 18**
5. Tighten the 5/8" bolts to specification, and re-check the Axle alignment from the trunnion tube to King-pin. **See figure 18**
6. Weld securely between tandem frame brackets (pedestals), and trunnion clamp castings. **See figure 17**
7. Tighten the trunnion clamp bracket fasteners to specification.
8. Install channel braces as shown in **figure 17**

SP Series

• Figure 18:

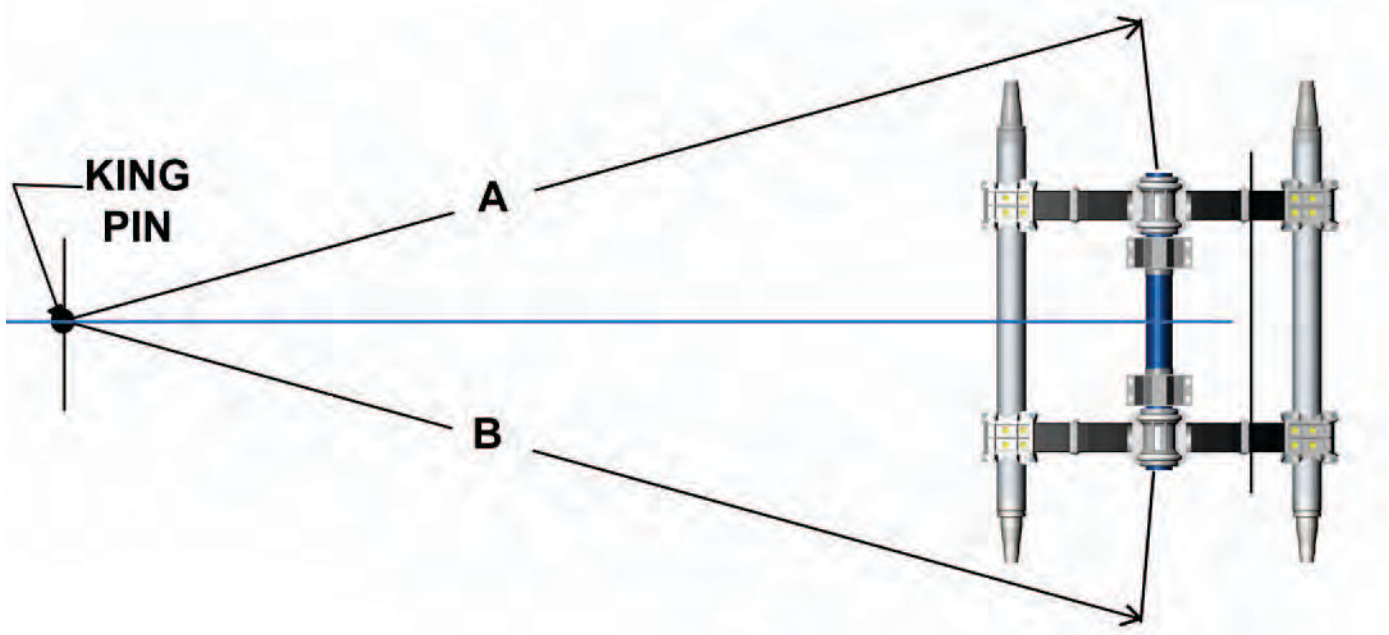

Axle Alignment

After suspension installation, the axles must be aligned in relation to the trailer kingpin.

- Measure the distance from the kingpin to the centerline of the front axle spindles. **See figure 19** Dimensions A and B must be equal to each other within 1/8".
- If dimensions A and B meet the specification, tighten the U-bolts and end cap bolts to specification on the front axle only. **See Torque Requirements Procedures**
- Next, measure the distance from the front axle to the rear axle at the center of spindles. **See figure 19** Dimensions C and D must be equal to each other within 1/16".
- If dimensions C and D meet the specification, tighten the U-bolts and end cap bolts to specification on the rear axle. **See Torque Requirements Procedures**
- Measure dimension E (lateral relationship of the suspension center line to the trailer frame center line) **See figure 19** Dimension E must not exceed 1/4". If adjustment is necessary, recheck dimensions A, B, C, and D.
- When all dimensions meet specification, tighten all U-bolts and nuts to specified values. **See Torque Requirements Procedures**

SP Series

A=B ± 1/8"
 C=D ± 1/16"
 E ≤ 1/4"

• Figure 19:

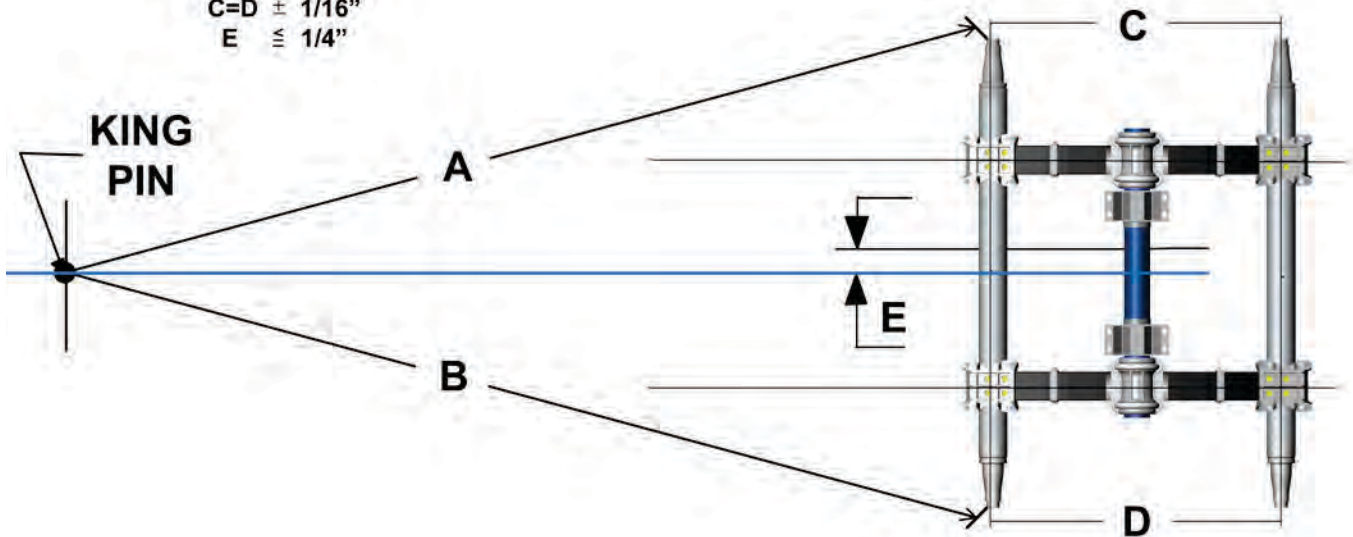

Weld Procedure

Caution

The welding procedures must be followed carefully to avoid damage to the axle and suspension which could cause an accident and/or serious personal injury. Some procedures differ for the "Slide Pad" version from those used for the WC standard version.

Watson & Chalin Standard Version Only

- Weld axles securely to Spring End Pad Castings, following the axle manufacturer's welding recommendations, using 3/8" fillet welds on the front and rear of the axle seats. Use welding rod AWS-Spec. E-70xx or equivalent. **See figure 20**

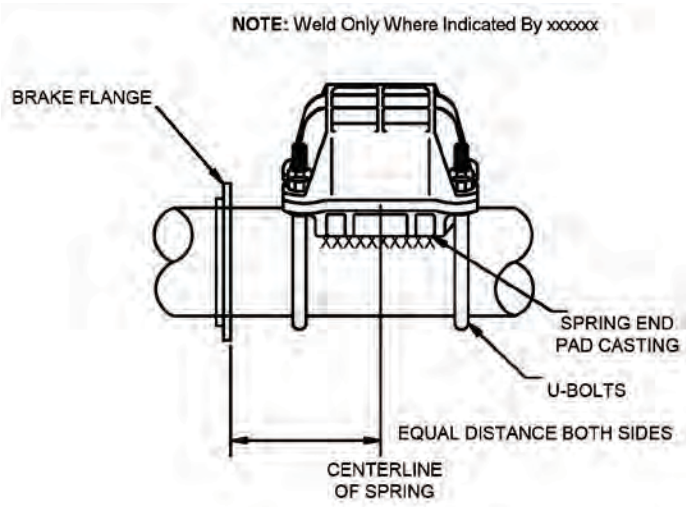

• Figure 20:

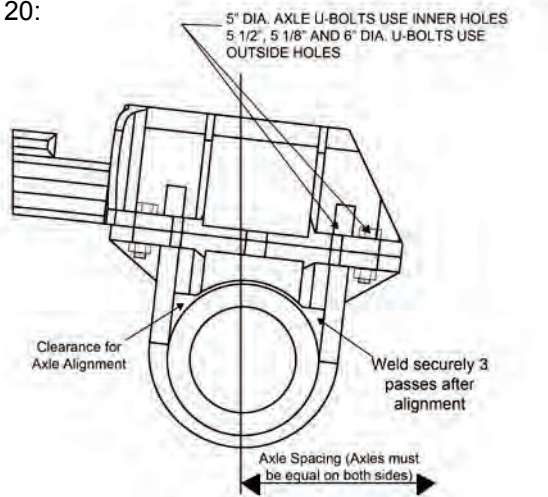

Caution

Prior to release of trailer you must verify that both Axle Seats of each axle are properly welded and all fasteners are securely torqued to the proper specifications. See "Torque Requirements Procedures" for proper torque and maintenance specifications.

SP Series

Slide Pad Version Weld Procedure

NOTE:

Watson & Chalin ships the Slide Pad version suspension with one side of each axle having the Slide Pad pre-welded to the Spring End Pad Castings.

After you have verified that the axles are fully aligned, you will need to weld the un-welded Slide pad and secure all U-Bolts and attachment bolts using required torque.

- Weld Slide Pad securely to Spring End Pad Castings, using 1/4" minimum fillet welds on the front and rear of the Spring End Pad Castings. Use welding rod AWS-Spec. E-70xx or equivalent.
- Weld Slide Pad securely to Spring End Pad Castings two places where indicated by XXXXXXX. See figure 21



Caution

Prior to release of trailer you must verify that both Slide Pads of each axle are properly welded and all fasteners are securely torqued to the proper specifications. See "Torque Requirements Procedures" for proper torque and maintenance specifications.

• Figure 21:

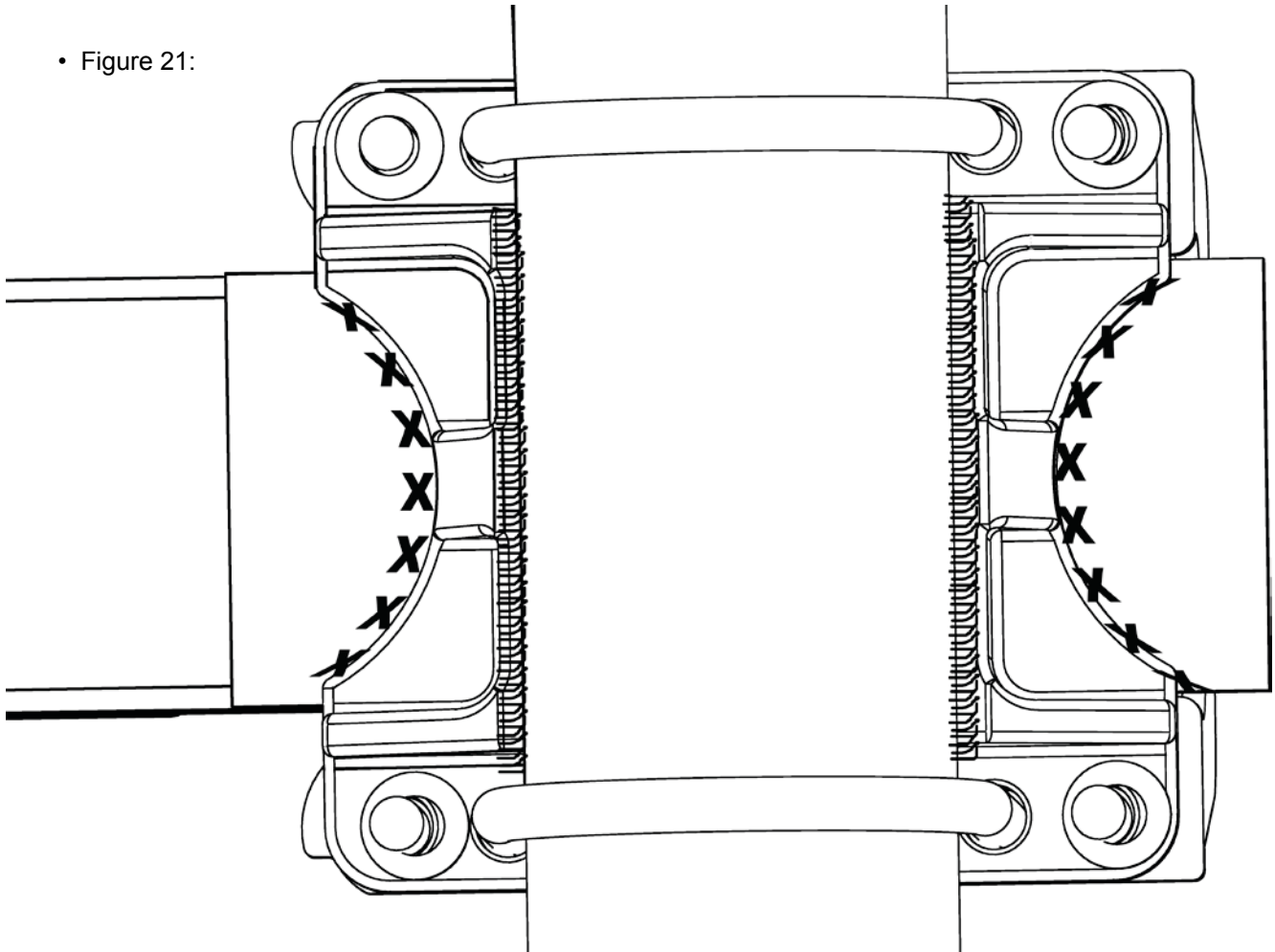

SLIDE PAD ONLY SPECIAL INSTRUCTIONS

Torque Requirements Procedures

Maintenance Procedures Literature Number: WC-M-1000



Torque Requirement Procedures

All fasteners should be re-torqued according to the following schedule.

- after 30 days
- every 6 months thereafter

Capscrew/Bolt (Grade 8 UNF) Torque Requirements

Capscrew/Bolt Size	3/8"	1/2"	5/8"	3/4"	3/4" (Stabilizer Shock Stud)	7/8"	1"	1 1/8"
Torque minimum feet/lbs.	25	50	150	300	150	500	700	900
Torque maximum feet/lbs.	35	75	200	350	175	550	800	1000

NOTE

Torque Values do not apply to air springs or lower grade fasteners.

U-bolt Torque Instructions

To torque or re-torque u-bolts:

1. Partially tighten bolts #1 and #2 according to figure 1.

Figure 1: U-Bolt Torque Pattern

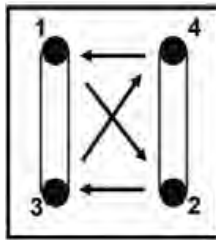

2. Partially tighten bolts #3 and #4.
3. Using the same sequence, torque to the proper torque as specified below.

UNF Grade 8 Size	3/8"	1/2"	5/8"	3/4"	7/8"	1"	1 1/8"
U-bolt minimum feet/lbs.	15	40	120	200	400	650	800
U-bolt maximum feet/lbs.	20	60	150	250	450	750	900

NOTES