

WATSON & CHALIN

Manufacturers of truck and trailer, steer and non-steer, auxiliary lift axles, trailer air ride and mechanical suspensions and loose trailer axles.

FULL LINE PRODUCT BROCHURE

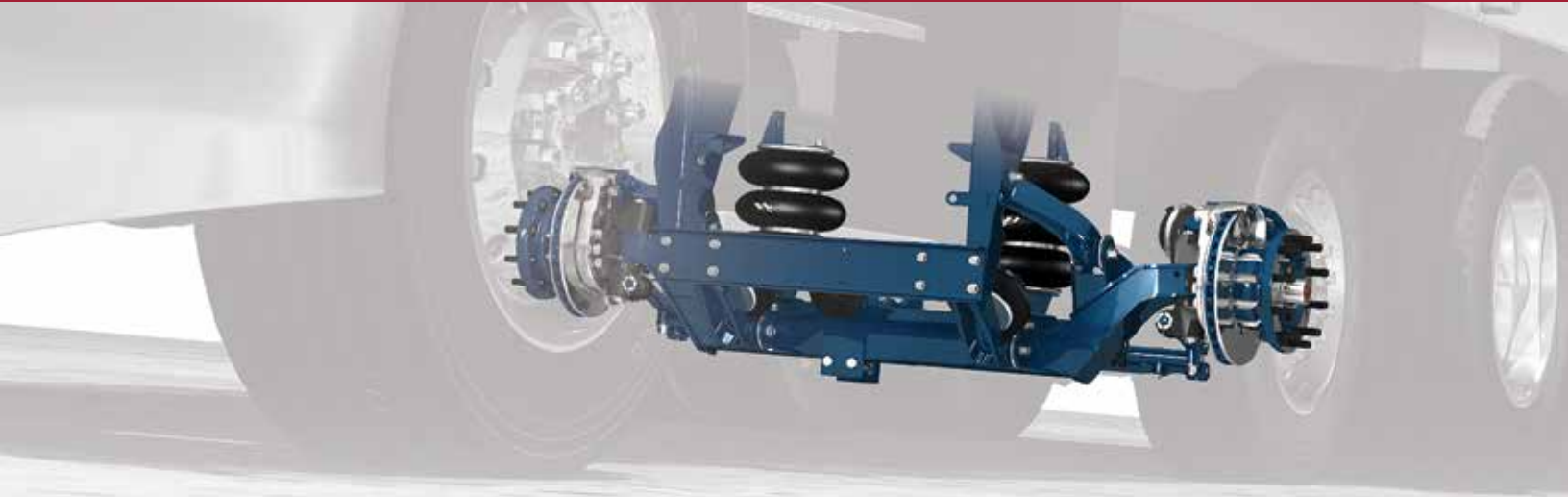

ENGINEERED RIDE SOLUTIONS

Watson & Chalin is a brand of Hendrickson

ENGINEERED **RIDE SOLUTIONS**

Watson and Chalin (W&C) is a pioneering, global supplier of truck and trailer lift axle systems; trailer suspension systems; specialty suspension systems; loose axles and components to the medium- and heavy-duty transportation industry. With a market focus and customer-driven approach, W&C is committed to delivering custom engineered ride solutions that are durable and reliable for demanding heavy-haul applications in the industry.

W&C is committed to the industry and invests in comprehensive research and development to help trucks and trailers benefit from improved uptime. Our operational excellence is guided by leadership principles in product development, quality workmanship and dedicated customer service. With this philosophy, we will create and sustain added value to exceed the demands of our customers.

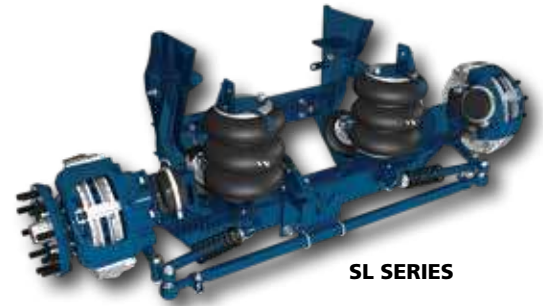

SL SERIES



TA SERIES

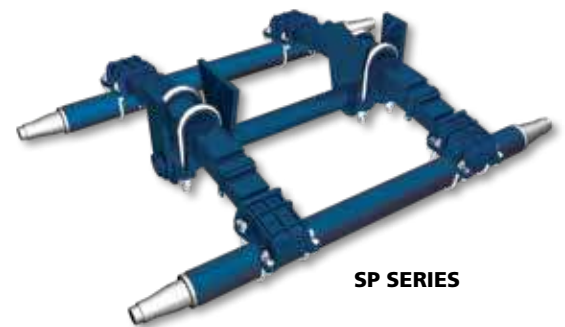

SP SERIES

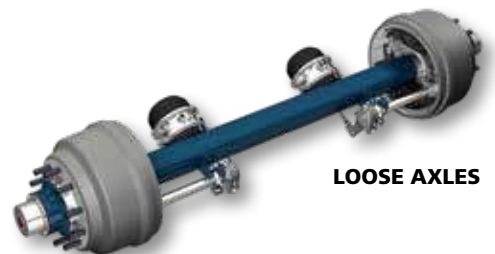

LOOSE AXLES

CONTENTS

LIFT AXLE SUSPENSION SYSTEMS 2

VALUE ADDED OPTIONS 4

TRAILER SUSPENSION SYSTEMS 6

LOOSE AXLES & LIFT KITS 8



SL — STEERABLE LIFT AXLES

- Capacities from 8,000 - 20,000 lbs.
- Parallelogram design for a constant axle caster
- Versatile, adjustable ride height and frame width features
- Minimized packaging space up to 22.1 in.
- Configurations available for all authorized lift axle applications

- Custom engineering available for specific customer requirements
- Backed by a 5-year limited warranty*

* Contact your local Watson & Chalin representative for complete warranty terms, conditions and limitations.

SL8K

Lightweight compact design, steerable lift axle suspension system

- Capacity of 8,000 lbs.
- Ride heights up to 19 in.
- Six stud hub for 17.5 in. wheels

Literature reference - W&C126



SL0893

SL10K

Lightweight compact design, steerable lift axle suspension system

- Capacity of 10,000 lbs.
- Ride heights up to 19 in.
- Eight stud hub for 19.5 in. wheels

Literature reference - W&C100



SL1093

SL13K

Our most popular capacity steerable lift axle suspension system

- Capacity 13,500 lbs.
- Ride heights up to 19 in.
- Ten stud hub for 19.5, 22.5 and 24.5 in. wheels
- Air disc brakes available

Literature reference - W&C106



SL1190

SL20K

Robust and innovative steerable lift axle suspension system

- Capacity of 20,000 lbs.
- Ride heights up to 14 in.
- Compatible with 445/65R22.5 tires
- Hub face of 89 in. for better body clearance

Literature reference - W&C180

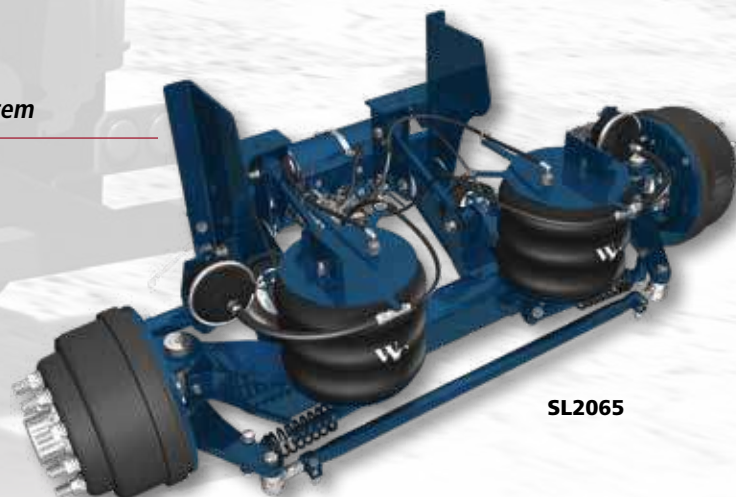

SL2065

SL25K

Steerable lift axle suspension system designed for use with dual or super single tires

- Capacity of 25,000 lbs.
- Ride heights up to 14 in.
- Compliant with Ontario, Canada "SPIF" regulations

Literature reference - W&C105

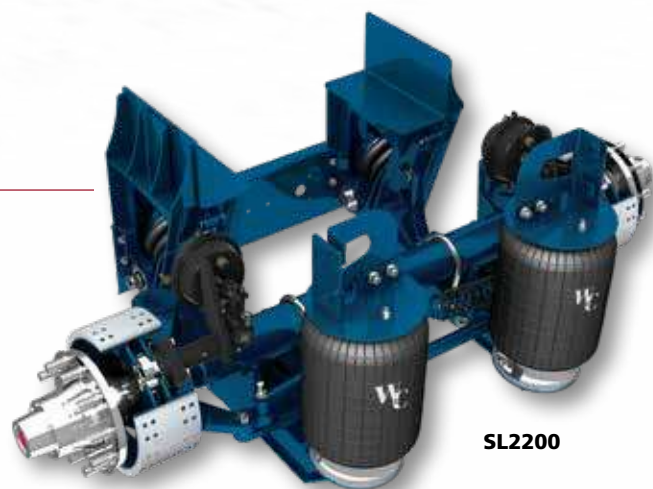

SL2200

AL — NON-STEERABLE LIFT AXLE

AL25K

Lift axle suspension system with outstanding performance and proven durability

- Capacity of 25,000 lbs.
- Ride heights up to 15 in.
- Two-pin axle connection with rubber bushings
- Positive axle stop straps
- Straight or drop axles

Literature reference - W&C101

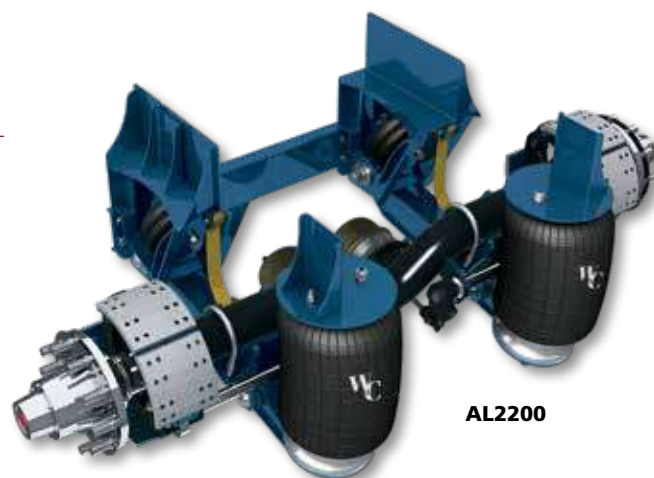

AL2200

Air Disc Brake

- Better stopping power
- Improved vehicle safety
- Higher and consistent brake torque output
- Increased service intervals (depending on the application)
- Better uptime while servicing brake pads

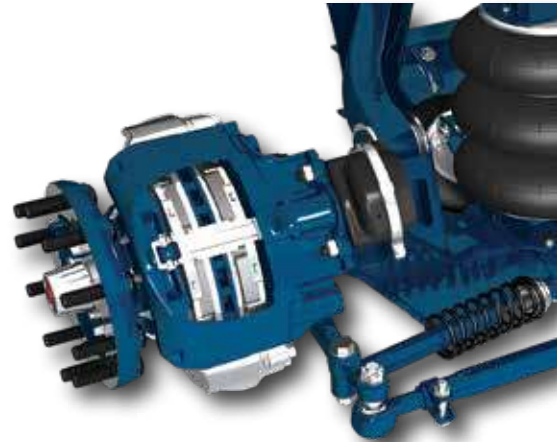

Pre-Plumbing System

- Fewer fittings reduces leak potential
- Better response when air is engaged
- Saves time and money during the installation
- 100 percent leak tested at the factory

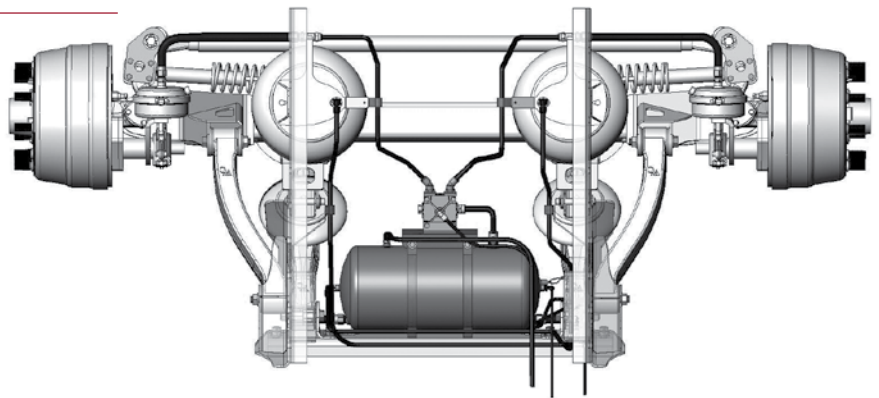

SL / AL SERIES QUICK REFERENCE (STANDARD MODELS)

MODEL	CAPACITY (LBS)	WEIGHT (LBS)	RIDE HEIGHT (IN)	LIFT (IN)	PACKAGE SPACE (IN)	HUB FACE (IN)	BRAKE SIZE	STUDS	WHEEL SIZE (IN)
SL8K	8,000	672	13 - 19	8	22.1	86	325 × 100mm	6	17.5
SL10K	10,000	719	13 - 19	8	22.1	89	325 × 100mm	8	19.5
SL13K	13,500	819	8 - 19	9	22.1	92	15 × 4, 16.5 × 5, Disc	10	22.5
SL20K	20,000	1,297	8 - 13	8.8	26.5	89	16.5 × 6 in.	10	22.5
SL25K	25,000	1,500	7 - 14	5	25	71.5 Track	16.5 × 7 in.	10	22.5
AL25K	Up to 25,000	1,222	8 - 15	7	25	71.5 Track	16.5 × 6 in.	10	22.5

Ride Height Adjustability

- Available on SL8K, SL10K, SL13K and SL20K (SL2065)
- Accomplished through interchangeable lower air spring plate
- Can also be used to limit lift if run height and driveline clearance fall within allowable criteria

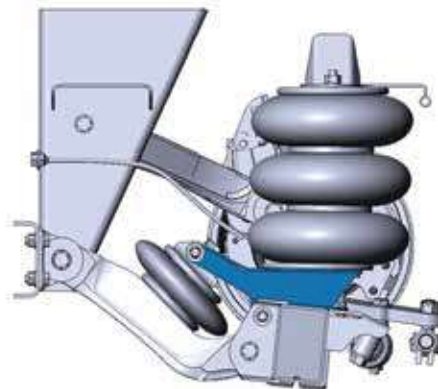

Ride Height Measurement Concept

- A.** Loaded Ground To Frame (GTF) Measurement
- B.** Static Loaded Radius (SLR) of tire
- C.** Ride Height ($A - B = C$)

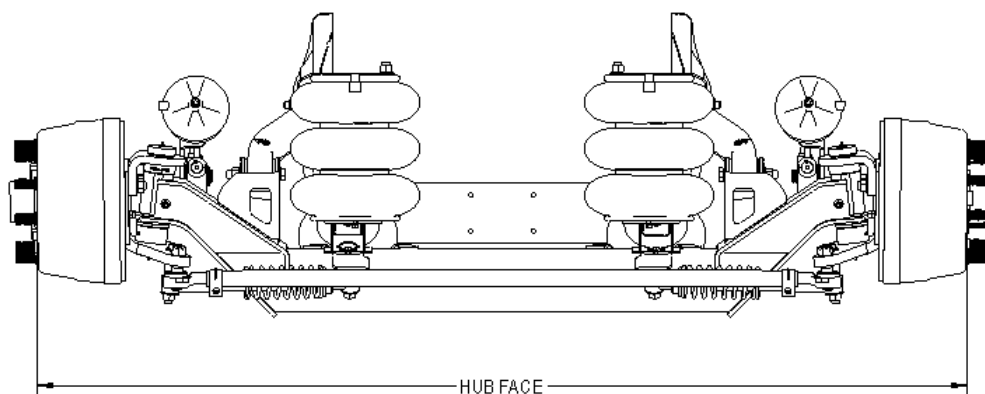
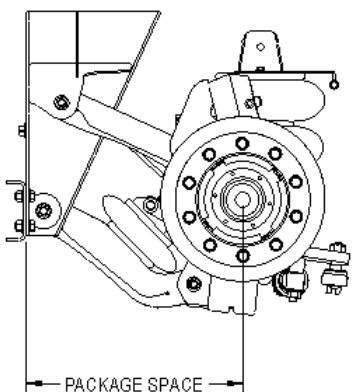
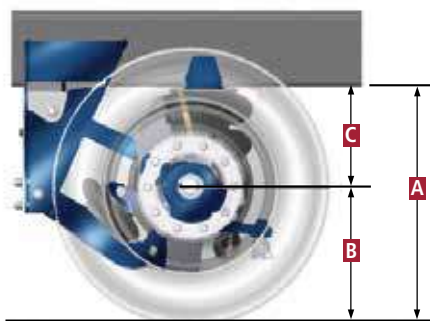

TA — TRAILER AIR SUSPENSIONS

- Proven technology for a wide range of applications
- Capacities of 25,000 - 30,000 lbs.
- Ride heights up to 19 in.
- Available as suspension kit or as an assembly with axles
- Special axle tracks available
- ALIGN-TRAC™ – Quick, easy alignment system
- 5-year limited warranty*

Literature reference - W&C107 and W&C109

* Contact your local Watson & Chalin representative for complete warranty terms, conditions and limitations.

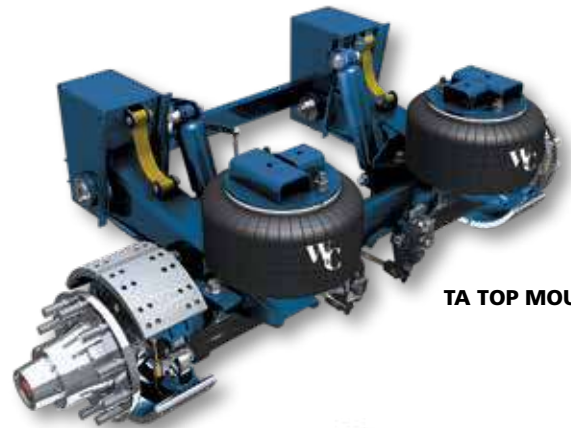

TA TOP MOUNT

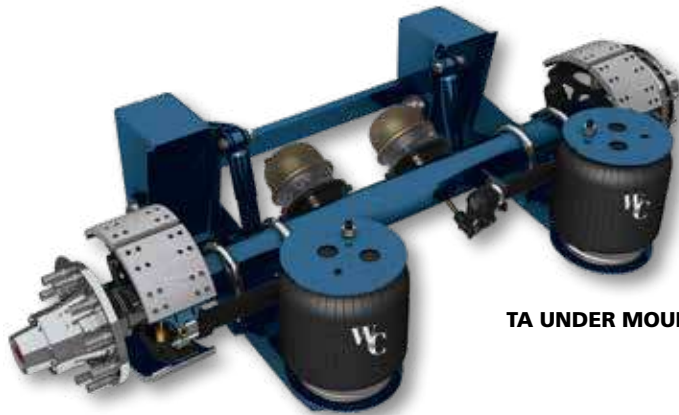

TA UNDER MOUNT

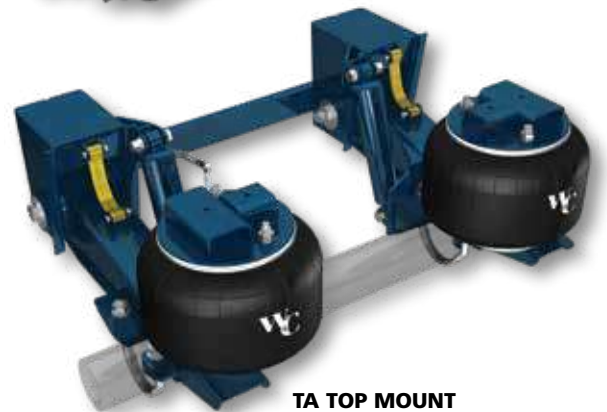

TA TOP MOUNT
SUSPENSION KIT

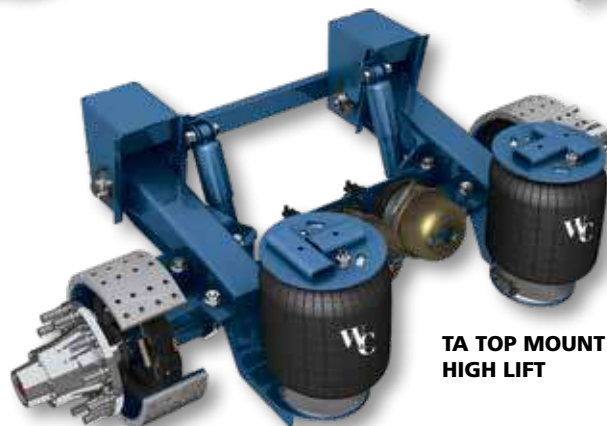

TA TOP MOUNT
HIGH LIFT

SP — SINGLE POINT SUSPENSIONS

- Strong spring trailer suspension for on- and off-highway trailer applications
- Capacity: 50,000 thru 80,000 lbs.
- Straddle or trunnion mount
- Severe-duty straddle plate available
- Optional trunnion lengths available
- Available as suspension kit or as an assembly with axles
- 5-year limited warranty*
- Applications: End Dump, Side Dump, Belly Dump, Logger, Container Chassis and more

Literature reference - W&C104 and W&C181

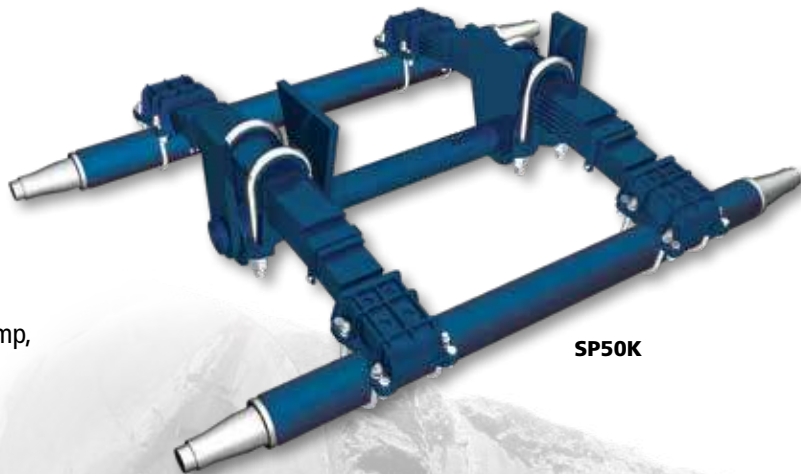

SP50K

Optional rubber bushing now available

MS — MULTI-SPRING SUSPENSIONS

- Rugged multi-spring trailer suspension for on- and off-highway applications
- Capacities up to 30,000 lbs. per axle
- Up to 49 in. axle spacing
- Single, tandem or tridem axle configuration
- Fabricated hangers and equalizers
- 5 in. diameter axle seats
- 1-year limited warranty*

Literature reference W&C102



MS2200

* Contact your local Watson & Chalin representative for complete warranty terms, conditions and limitations.

LOOSE AXLES

Offering a full line of axles which helps to finalize the full line of trailer suspensions such as the TA, Single Point and Multi-Spring families.

- Axle capacity up to 25,000 lbs.
- Straight, 6- or 9-in. drop
- Axle tracks: 71.5- and 77.5-in. standard
- Axle wall: 1/2-, 5/8- and 3/4-in.
- N or P spindles
- Air disc brakes available
- Special axle tracks available
- Tire inflation system available

Literature reference - W&C157



TRAILER LIFT KITS

- Different designs depending on specific applications
- Configurations for limited ground clearance or frame space
- Air control kits available for correct operation

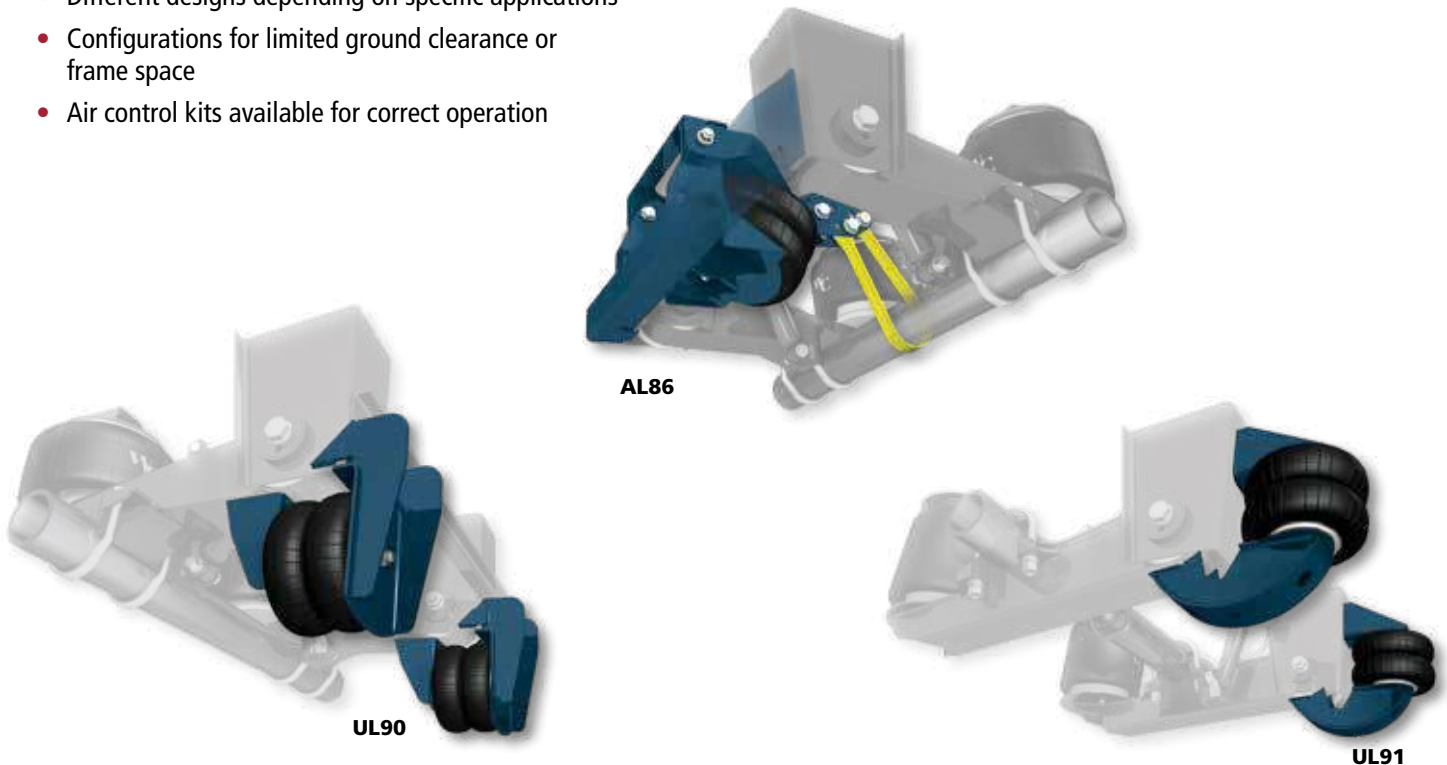



RESEARCH & DEVELOPMENT

Capabilities

Watson and Chalin's (W&C) business spans for more than 30 years and has been a brand of Hendrickson since 2006. Since then our product offering and capabilities have expanded with manufacturing excellence initiatives and a state-of-the-art R&D facility fostering new product development. We are dedicated to providing engineered ride solutions, ensuring low life-cycle cost and maximum uptime for our customers.

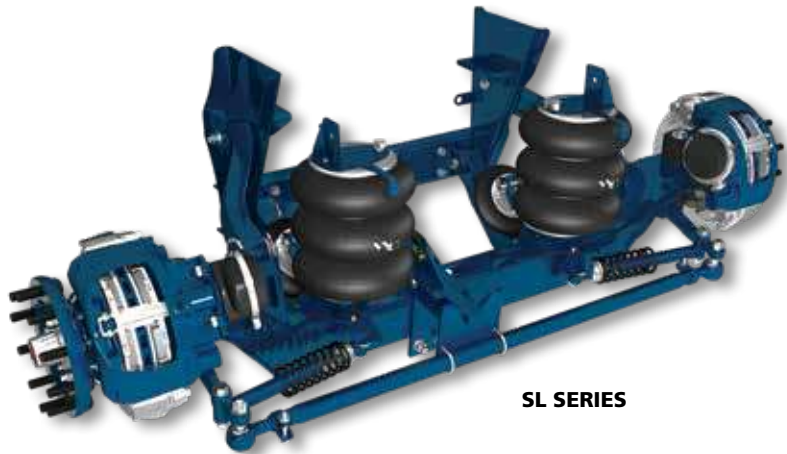

SL SERIES

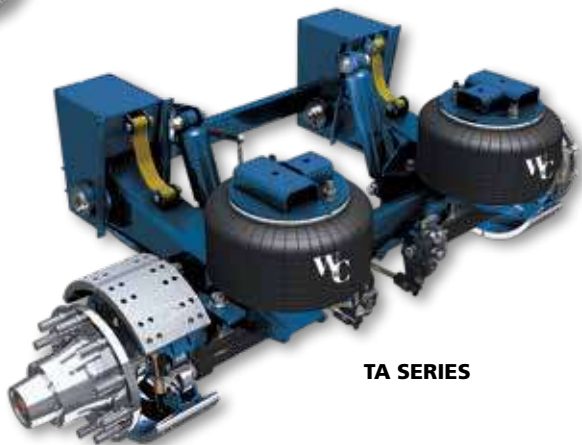

TA SERIES

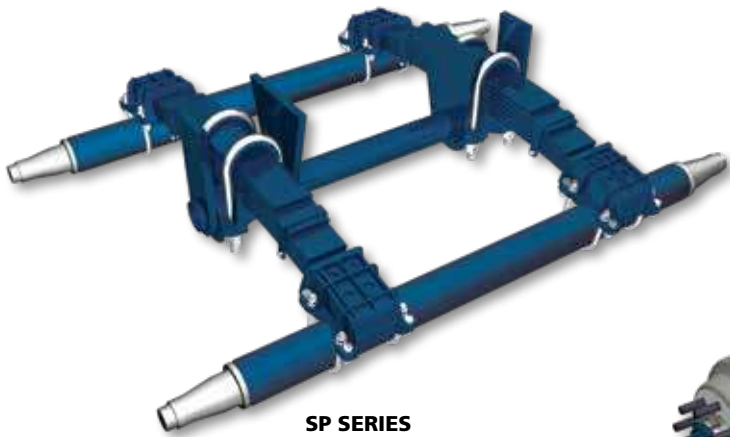

SP SERIES

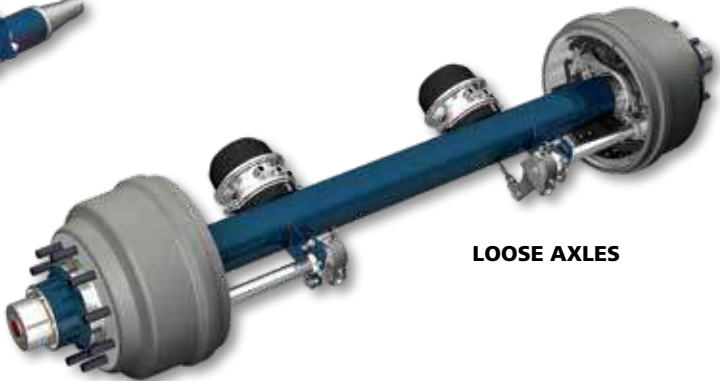

LOOSE AXLES

ENGINEERED RIDE SOLUTIONS



Watson & Chalin
725 E. University Drive, McKinney, Texas 75069
972.547.6020 • 800.445.0736 • Fax 972.542.0097
www.watsonsuspensions.com

