











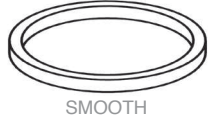
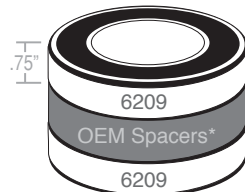



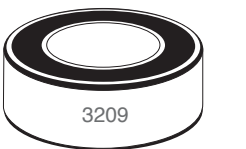
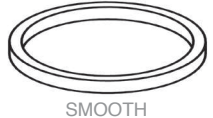

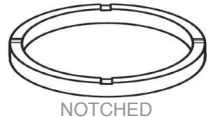
POSSIBLE BEARING CONFIGURATIONS

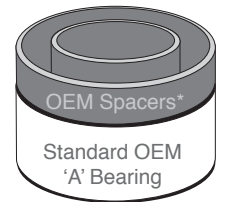
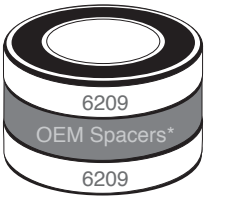
IF YOU TAKE OUT:	PUT IN:	USE THIS BEARING SHIM:	KIT #
		 SMOOTH	14-256 24-256
		 SMOOTH	14-256 24-256
		 SMOOTH	14-256-1 24-256-1
		 NOTCHED	14-256 24-256
 OR 		 NOTCHED	14-256 24-256
<small>OEM Spacers might be above or below bearings.</small>			
		 NOTCHED	14-256 24-256
 OR 		 NOTCHED	14-256 24-256
<small>OEM Spacers might be above or below bearings.</small>			

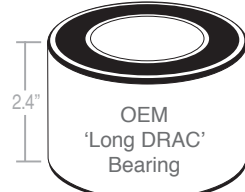
*OEM Spacers heights vary. Always reuse any and all bearing spacers from OEM fan clutch. Bearing spacers always come in pairs - an inner and outer race. Failure to use both spacers will cause bearing failure.

** .85\" Spacers are now included with GoldTop fan clutch kits. If you require these spacers and your GoldTop did not come with them, call us at 800-810-9110.

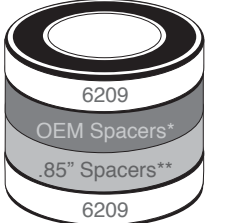
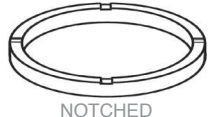
GoldTop
by Kit Masters



GoldTop™ Assembly Instructions 14-256 & 14-200

ALWAYS replace bearings when rebuilding your fan clutch.



Be sure to check the air pressure being supplied to your fan clutch. Must have 90-120 psi to fully disengage.

DISASSEMBLY

- Using the T-55 Torx bit provided, remove the friction plate. The plate will say left hand thread but the center bolt should be turned like a standard bolt – turn the T-55 Torx bit COUNTER CLOCKWISE while holding the friction plate from rotating. It will help to apply air pressure to the clutch while removing the friction plate.
- Once the friction plate is removed, hand-tighten the black plastic cage on the left hand threaded bolt. If you applied air pressure in step 1 - remove it now.
- Remove the Friction Facing Screws (1) with a T-27 Torx bit. Remove the lining and throw it away.
- Remove the Aluminum Spring Housing (2). Use two flat screwdrivers to pry the Aluminum Spring Housing from the pulley and throw it away.
- Remove the large Black Seal (3) and throw it away.
- Remove the Retaining Ring (4) and throw it away.
- Remove the Air Chamber Cap (5) and throw it away.
- Remove the Air Cartridge Snap Ring (6) and throw it away.
- Remove the Air Cartridge Assembly (7) and throw it away.
- Remove the Bearing Nut with a 2\" socket and throw it away. The pulley will now slide off the shaft.
- NOTE: When removing bearings and spacers in the next step, be sure to note the current configuration. Then, refer to the Bearing Configuration Chart on page 4 to determine the correct configuration for your clutch.*
- Press out the bearings - SAVE ANY SPACERS FOUND INSIDE OF THE PULLEY. Clean and inspect the pulley inside and out.
- Clean and inspect the shaft inside and out. Clean and chase the threads on shaft.

INSTALLATION

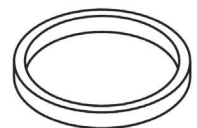
- Note: Bearings must be pressed in on the outer race.
- Press in one of the new bearings into the pulley. Then insert any and all required spacers as shown on page 4 (if there were spacers in the pulley during disassembly, you must reuse both of them between the new bearings). Next, press in the second bearing. *NOTE: Kit # 14-256-1 has only one bearing in the kit and may NOT be used in place of kit # 14-256.*
- Determine the required bearing shim: If you removed two bearings (6209) during disassembly, use the bearing shim without notches in it. If you removed one double row bearing during disassembly, use the bearing shim with the four notches in it.

 OR 
- Install bearing shim & retaining ring.
- Install pulley over the journal bracket.
- With the shoulder of the bearing nut facing toward the sheave bearing (see assembly illustration) – torque to 125 Ft Lbs.
- Apply lube to the three o-rings on the air cartridge assembly and install the new air cartridge assembly in the journal bracket.
- Install the new snap ring over air cartridge assembly.
- Assure that the threads in the eight holes in the pulley are clean. Align the eight holes in the GoldTop™ Main Assembly with the eight holes in the pulley. Torque the eight T-27 screws to 80 inch lbs.
- When installing your fan, the fan blade nuts should be torqued with no more than 35 Ft. Lbs.

Patent(s) Pending. See www.kit-masters.com for updated list of applicable issued and pending patents.
Video demonstration available at www.kit-masters.com • For installation assistance, contact Kit Masters at (800)-810-9110
Instrucciones en Español en www.kit-masters.com/instructions.php

DISASSEMBLY

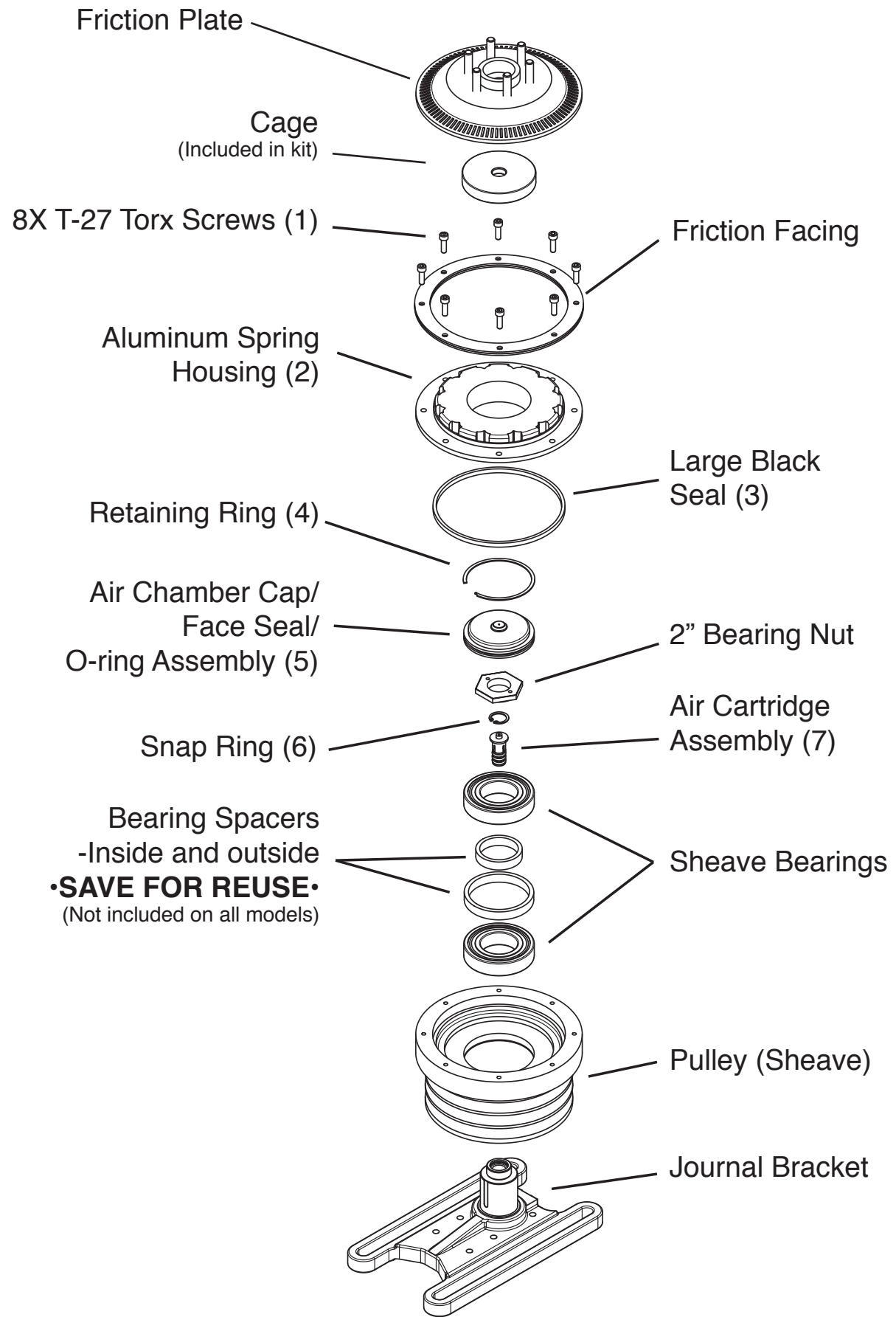

ASSEMBLY

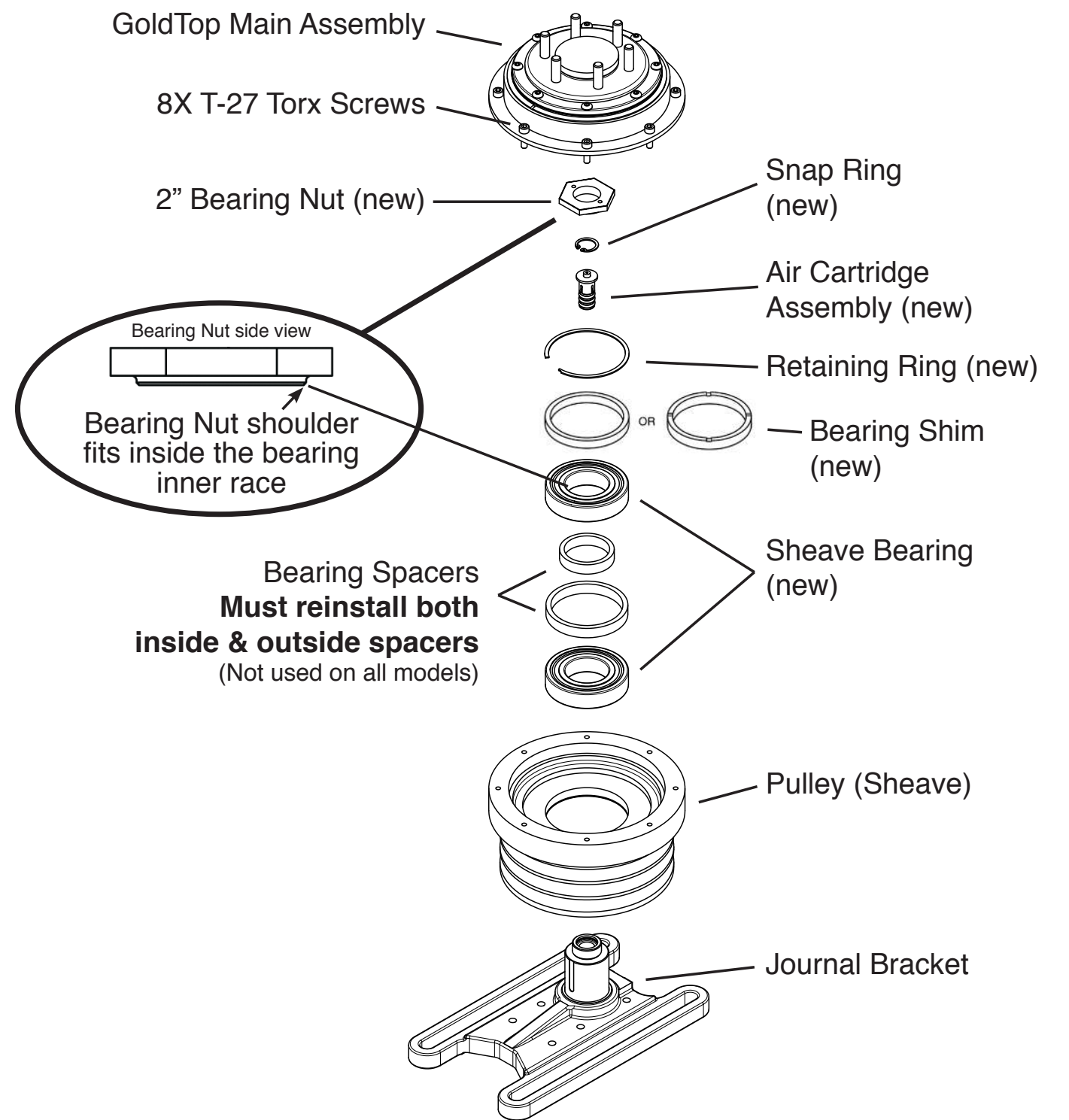

KIT MASTERS
FAN CLUTCH EXPERTS
www.KitMasters.com