

KIT MASTERS

FAN CLUTCH EXPERTS

4205 Seal Kit Installation Instructions

Pieces included in kit

Reusable pieces

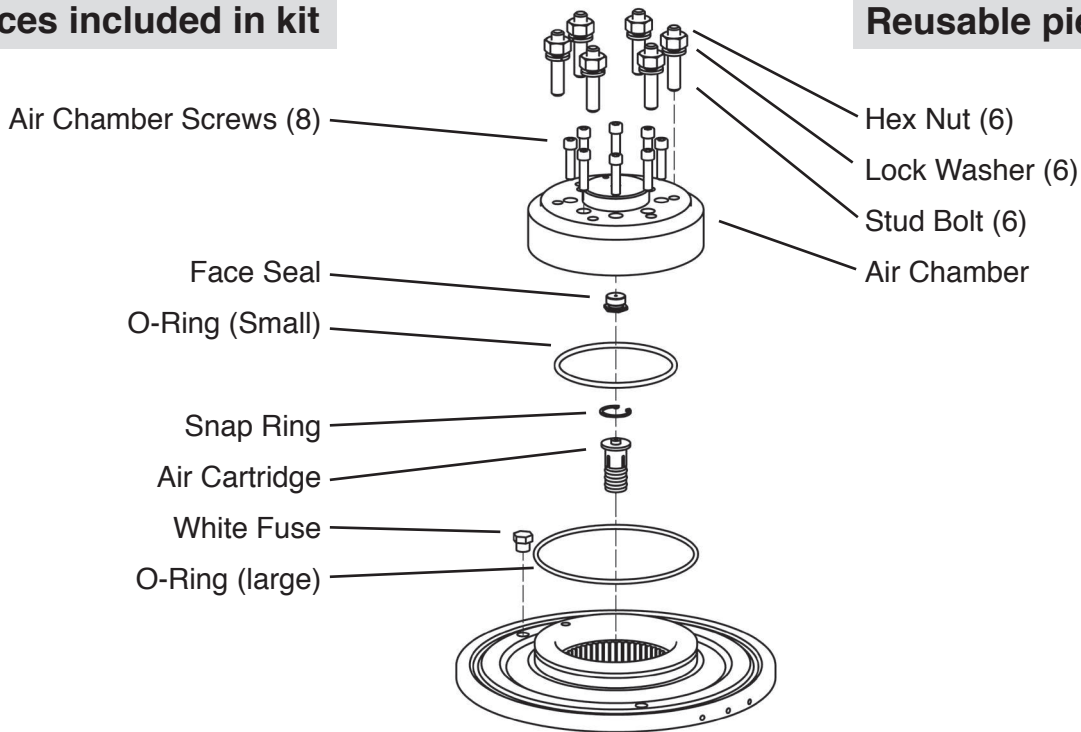

DISASSEMBLY

1. Remove Torx screws from air chamber.
2. Remove air chamber from fan clutch.
3. Holding air chamber upside-down, remove o-ring and face seal.
4. Remove large o-ring from friction plate.
5. Using a snap ring pliers, remove the snap ring from the center of the shaft.
6. Remove old air cartridge.

INSTALLATION

1. Clean all pieces with a wire brush and cleaning solution.
2. Apply o-ring lube to large o-ring and install on friction plate.
3. Apply o-ring lube to small o-ring and install on air chamber.
4. Apply o-ring lube on air cartridge and install new air cartridge in journal bracket.
5. Install new snap ring over air cartridge.
6. Place air chamber over friction plate.
7. Install and tighten air chamber Torx screws to 180 inch-pounds torque.
8. If your friction plate is equipped with a fuse, and it has not blown (doesn't leak), you do not need to replace it. If the fuse needs to be replaced, replace it with the new white fuse included in your kit. **THE FUSE IS LEFT HAND THREADED.**