



Brake and Wheel Products

# 55k & 62k Capacities

## Standard Mount

# LANDING GEAR

### 3 Gear / 2 Speed Operation



**LG-6200 Series**  
Self-leveling foot (shown)

## LG-5500 Series

- 55,100 lb. lift capacity
- 132,000 lb. load capacity
- Sets available with 17" or 19" lift
- 4.5" sand shoe, 2" low sand shoe or self-leveling foot
- Greasable shafts and gears
- 1 year warranty

## LG-6200 Series

- 61,700 lb. lift capacity
- 176,300 lb. load capacity
- Sets available with 17" or 19" lift
- 4.5" sand shoe, or self-leveling foot
- Greasable shafts and gears
- 1 year warranty



**LG-5500 Series**  
4.5" Standard Sandshoe (shown)



**LG-WBR Bracket**

Special W Bracket used to accommodate the superior leg design



Batco® brand Brake and Wheel Products from Dayton Parts, LLC

# 55k & 62k Standard Mount Landing Gear

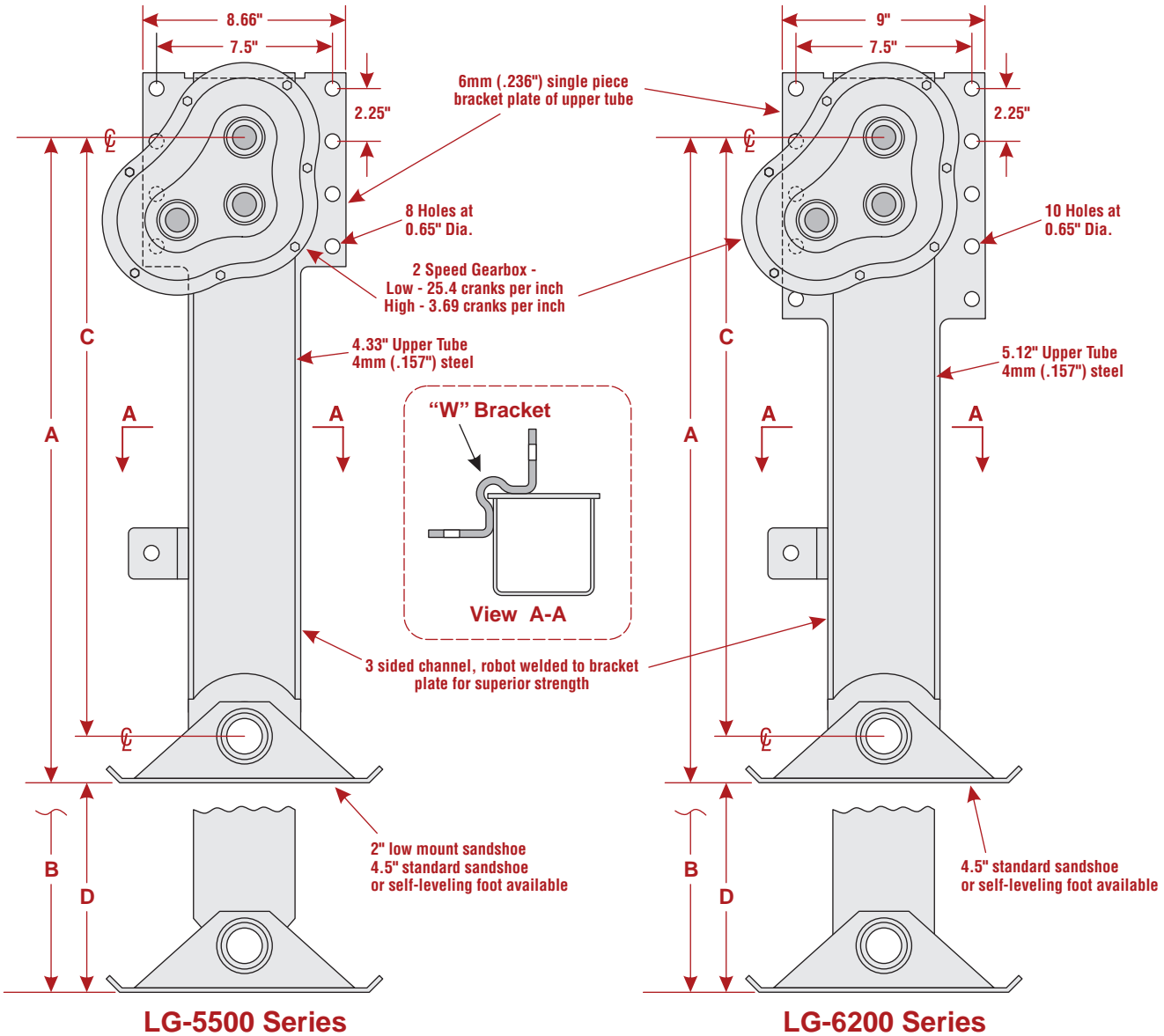

Part No.	Shoe Description	Retracted (A)	Extended (B)	C to C (C)	Lift (D)	Kit Part No.
<b>LG-5500 Series</b>						
LG-5517LS	Sand Shoe, 2.1" High	27.7"	44.6"	25.6"	16.9"	LG-5517LSK*
LG-5519LS	Sand Shoe, 2.1" High	29.7"	48.6"	27.6"	18.9"	LG-5519LSK*
LG-5517SS	Sand Shoe, 4.5" High	30.1"	47.0"	25.6"	16.9"	LG-5517SSK*
LG-5519SS	Sand Shoe, 4.5" High	32.1"	51.0"	27.6"	18.9"	LG-5519SSK*
LG-5517RF	Self-Leveling, 9.8" Sq.	29.1"	46.0"	25.6"	16.9"	LG-5517RFK*
LG-5519RF	Self-Leveling, 9.8" Sq.	31.0"	49.9"	27.6"	18.9"	LG-5519RFK*
<b>LG-6200 Series</b>						
LG-6217SS	Sand Shoe, 4.5" High	30.3"	47.2"	25.8"	16.9"	LG-6217SSK*
LG-6219SS	Sand Shoe, 4.5" High	32.3"	52.2"	27.8"	18.9"	LG-6219SSK*
LG-6217RF	Self-Leveling, 9.8" Sq.	30.3"	47.2"	25.8"	16.9"	LG-6217RFK*
LG-6219RF	Self-Leveling, 9.8" Sq.	32.2"	51.1"	27.8"	18.9"	LG-6219RFK*

Retracted Height (A) is measured from Cross Shaft Center Line to the Bottom of the Foot at Full Retraction.  
 Extended Height (B) is measured from Cross Shaft Center Line to the Bottom of the Foot at Full Extension.

\*Kits include: (2) LG-WBR Brackets, (1) 11-0103 Crank, (1) 11-0155 Cross Shaft

