

# Extreme Air™

## High Performance Height Control Valve

### Features

- ◆ Minimal deadband
- ◆ All push-to-connect fittings
- ◆ Universal mounting
- ◆ Quick & accurate operation
- ◆ Dump and non-dump configurations
- ◆ 2-year warranty
- ◆ Competitively priced

### Benefits

*Ridewell's high performance height control valve for trucks, trailers, buses, and recreational vehicles responds quickly to correct air pressure and return vehicle to desired ride height.*

*The maintenance-free valve is designed with a universal mounting to work with all applications*

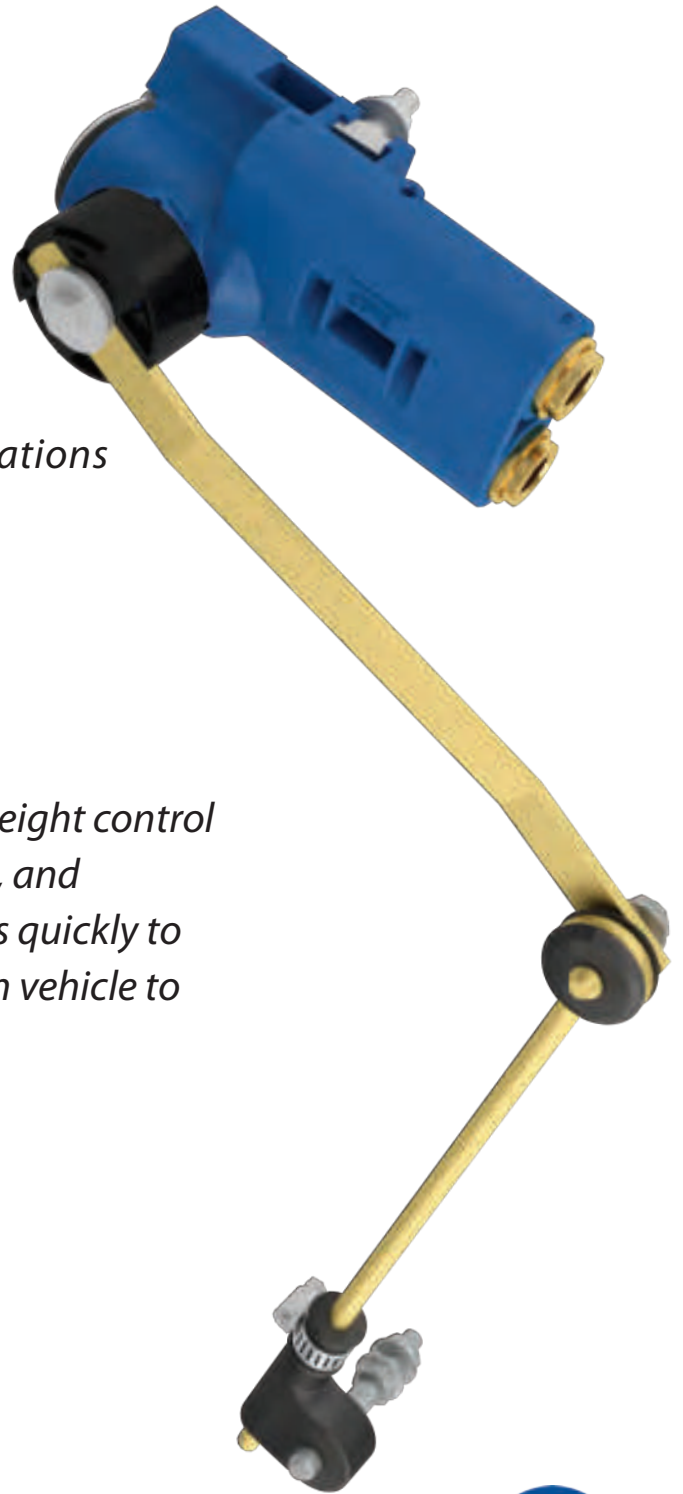

# Extreme Air™

## High Performance Height Control Valve

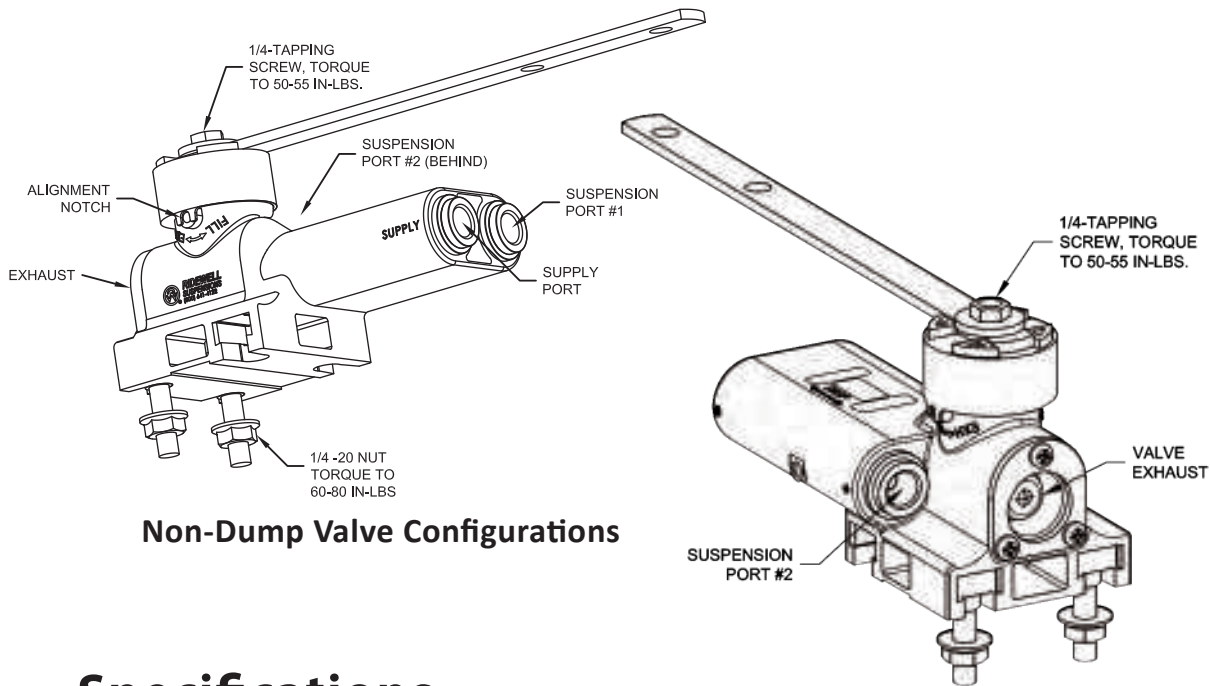

**Non-Dump Valve Configurations**

## Specifications

<b>Dampening</b>	None	<b>Exhaust Flow</b>	7CFM at 10 degrees
<b>Dead Band</b>	+/- 1.5 degrees	<b>Exhaust Angle Limit</b>	Full Travel 180 degrees
<b>Centering</b>	+/- 2 degrees	<b>Dump Flow</b>	30+ CFM (.25 flow dia.)
<b>Fill Flow</b>	12.5 CFM 10 degrees	<b>Operating Pressure Max.</b>	150 psi
<b>Fill Flow Vehicle on Bumpers</b>	17 CFM max.	<b>Temperature Range</b>	-40F to 150F
<b>Fill Angle Limit</b>	Full Travel	<b>Lever Mounting</b>	4 directions
		<b>Base Weight (non-dump)</b>	12.2 oz (includes lever/studs)

## Dump Valve Configurations (shown with optional offset lever)

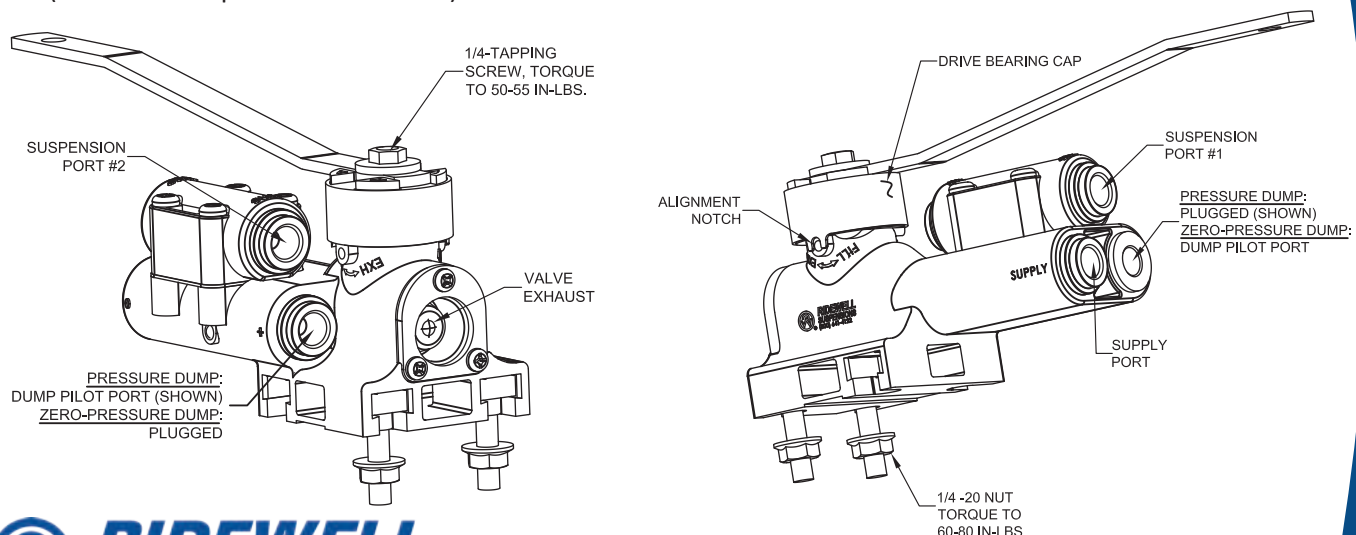

**RIDEWELL  
SUSPENSIONS**

P.O. Box 4586 ♦ Springfield, Missouri 65808  
www.ridewellcorp.com ♦ 800.641.4122 ♦ Fax 417.833.4560